

January 31, 2007

Eagle Cap Inc.
3225 Lavina Drive
Forest Grove, OR 97116

Re: Refund for Street Trees

Dear Sir:

The City has completed its latest street tree installation project. As with past projects, not all the trees that were paid for could be installed due to conflicts with utilities, etc. At 367 Bluejay Ave. (1) and 366 Bluejay Ave. (1) not all the trees could be installed. Therefore, enclosed is a check in the amount of \$572.00 that represents your refund.

If you have any questions, please contact me at (503) 992-3233.

Sincerely,

James Reitz, AICP
Associate Planner

Enclosure: Check for \$572.00



COMMUNITY DEVELOPMENT DEPARTMENT
Building and Code Enforcement

INSPECTION REQUEST

503-992-3206

Site Address 366 Bluejay
Contractor John
Phone Number 503-522-1571

Scheduled Inspection Date 7-26-06
Mon [] Tues [] Wed [x] Thurs [] Fri []
AM [] PM [] other []
Permit Number BU05-00096

- BUILDING: Footing / Pier, Foundation Wall, Underfloor (P & B), Shear, Framing, Insulation, Approach/Sidewalk, Other, Planning, Final [x] RE
PLUMBING: Underfloor (P & B), Top Out (Rough), Water Line, Rain/Crawl Drains, Storm Drainage, Sanitary Sewer, Backflow Device, Water Heater, Other, Final
MECHANICAL: Gas Piping, Underfloor (P & B), Rough Mechanical, HVAC (Final), Other, Comments:
MANUFACTURED HOME: M/H Set-Up, M/H Mechanical, M/H Water/Sewer, M/H Electrical Feeder, M/H Final, Other

- [] APPROVED [] NOT APPROVED (REINSPECTION REQUIRED) [x] APPROVED AFTER CORRECTIONS [] REINSPECTION FEE IS REQUIRED BEFORE NEXT INSPECTION \$

CORRECTIONS: 1) PROVIDE PERMANENT OPERABLE HARDWARE @ CRAWL ACCESS @ REAR of house

OK to occupy

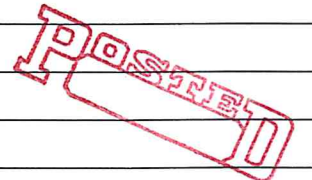

Date: 7-26-06 Inspector: AWL



COMMUNITY DEVELOPMENT DEPARTMENT
Building and Code Enforcement

INSPECTION REQUEST

503-992-3206

Site Address 366 BLUEJAY
Contractor JOHN
Phone Number 503-357-2490

Scheduled Inspection Date 03/30/06
Mon [] Tues [] Wed [] Thurs [] Fri []
AM [] PM [] other
Permit Number BND05-000916

Table with 4 columns: BUILDING, PLUMBING, MECHANICAL, MANUFACTURED HOME. Includes checkboxes for various inspection items like Footing/Pier, Underfloor, Gas Piping, etc.

Comments [PUNCH LIST GENERATION ONLY]

APPROVED [] NOT APPROVED [X] (REINSPECTION REQUIRED)
APPROVED AFTER CORRECTIONS [] REINSPECTION FEE IS REQUIRED BEFORE NEXT INSPECTION \$

CORRECTIONS: NOTE: SUB-DIVISION HAS NOT BEEN APPROVED BY VARIOUS CITY DEPARTMENTS. THIS INSPECTION DOES NOT GRANT APPROVAL TO OCCUPY HOME, NOR ALLOW MOVING-IN OF PERSONAL PROPERTY BY OWNER. ONCE SUB-DIVISION HAS BEEN APPROVED A REQUEST FOR FINAL RE-INSPECTION MUST BE MADE PRIOR TO ANY OCCUPANCY. MR. MANUELY BUILDING OFFICIAL 03/30/06

- 1 Insulate water shutoff's in GARAGE
2 1" clearance from 3" on wtr HTR to Insulation on PIPE
3 Attach Deck ledger w/ lags as PERH. SD2.2.1
4 GRADE Dirt Around From Building @ 2% slope at rear
5 EXTEND DRYER EXHAUST TO FACE OF CABINET

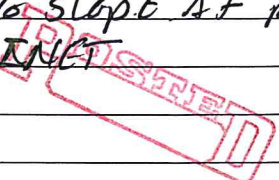

Date: 3.30.06 Inspector: [Signature]

5-J's Construction Services, LLC
 1018 Elm Street
 Forest Grove, OR 97119
 Office: 503-359-1303 • Fax: 503-359-0648

	R-VALUE	THICKNESS	MANUFACTURER
WALLS			
Exterior:	R21	5 1/2"	JM
Garage:			
Common:			
Sound:			
FLOORS			
Cantilevers:			
Over Garage:	R25	8"	JM
Under Floor:	R25	8"	JM
VAULTED CEILINGS			
House Loosefill:	R30	12"	Certain Teed
Garage Loosefill:			
House Batt:	R30	10"	JM
Garage Batt:			
FLAT CEILINGS			
House Loosefill:	R38	14 3/4"	Certain Teed
Garage Loosefill:			
House Batt:	R38	12"	JM
Garage Batt:			
BUILDER:	Eagle Cap		
ADDRESS:	304 Bluejay - Forest Grove		

Street tree



COMMUNITY DEVELOPMENT DEPARTMENT
Building and Code Enforcement

INSPECTION REQUEST

503-992-3206

Site Address 3660 Bluejay
Contractor
Phone Number

Scheduled Inspection Date 5/26/06
Mon [] Tues [] Wed [] Thurs [] Fri [x]
AM [] PM [] other
Permit Number BLD05-00046

BUILDING

PLUMBING

MECHANICAL

MANUFACTURED HOME

- Footing / Pier
Foundation Wall
Underfloor (P & B)
Shear
Framing
Insulation
Approach/Sidewalk
Other
Planning
Final

- Underfloor (P & B)
Top Out (Rough)
Water Line
Rain/Crawl Drains
Storm Drainage
Sanitary Sewer
Backflow Device
Water Heater
Other
Final

- Gas Piping
Underfloor (P & B)
Rough Mechanical
HVAC (Final)
Other

- M/H Set-Up
M/H Mechanical
M/H Water/Sewer
M/H Electrical Feeder
M/H Final
Other

Comments:

[x] APPROVED

[] NOT APPROVED
(REINSPECTION REQUIRED)

[] APPROVED AFTER
CORRECTIONS
(NO REINSPECTION REQUIRED)

[] STOP WORK

CORRECTIONS:



Date: 5/26/06

Inspector: [Signature]



COMMUNITY DEVELOPMENT DEPARTMENT
Building and Code Enforcement

INSPECTION REQUEST

503-992-3206

Site Address 366 Bluejay
Contractor John
Phone Number

Scheduled Inspection Date 3-23-06
Mon [] Tues [] Wed [] Thurs [x] Fri []
AM [] PM [] other
Permit Number Plm 05-00103

BUILDING

PLUMBING

MECHANICAL

MANUFACTURED HOME

- Footing / Pier
Foundation Wall
Underfloor (P & B)
Shear
Framing
Insulation
Approach/Sidewalk
Other
Planning
Final

- Underfloor (P & B)
Top Out (Rough)
Water Line
Rain/Crawl Drains
Storm Drainage
Sanitary Sewer
Backflow Device
Water Heater
Other
Final

- Gas Piping
Underfloor (P & B)
Rough Mechanical
HVAC (Final)
Other

- M/H Set-Up
M/H Mechanical
M/H Water/Sewer
M/H Electrical Feeder
M/H Final
Other

APPROVED [] NOT APPROVED [x] APPROVED AFTER CORRECTIONS [] STOP WORK []
Comments: 8 (Also Backflow)

APPROVED [] NOT APPROVED [x] APPROVED AFTER CORRECTIONS [] STOP WORK []
(REINSPECTION REQUIRED) (NO REINSPECTION REQUIRED)

CORRECTIONS: watts model 775QT 1" DC
serial # 41849 Located NE corner of lot
10' south of side walk

~~at~~ Hall Bath over 120 degrees adjust mixing
valve at tub
check master shower also (p215)



Date: 3-23-06 Inspector: [Signature]



COMMUNITY DEVELOPMENT DEPARTMENT
Building and Code Enforcement

INSPECTION REQUEST

503-992-3206

Site Address: 366 Bluejay Ave
Contractor:
Phone Number: 357-2490

Scheduled Inspection Date: 3-23-06
Mon [] Tues [] Wed [] Thurs [] Fri [x]
AM [] PM [] other:
Permit Number: 0500094

- BUILDING: Footing / Pier, Foundation Wall, Underfloor (P & B), Shear, Framing, Insulation, Approach/Sidewalk, Other, Planning, Final
PLUMBING: Underfloor (P & B), Top Out (Rough), Water Line, Rain/Crawl Drains, Storm Drainage, Sanitary Sewer, Backflow Device, Water Heater, Other, Final
MECHANICAL: Gas Piping, Underfloor (P & B), Rough Mechanical, HVAC (Final), Other
MANUFACTURED HOME: M/H Set-Up, M/H Mechanical, M/H Water/Sewer, M/H Electrical Feeder, M/H Final, Other

Comments: Key in electrical meter

[x] APPROVED [] NOT APPROVED (REINSPECTION REQUIRED) [] APPROVED AFTER CORRECTIONS (NO REINSPECTION REQUIRED) [] STOP WORK

CORRECTIONS: corrections completed

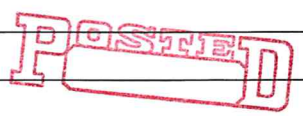

Date: 3.23.06 Inspector: [Signature]



COMMUNITY DEVELOPMENT DEPARTMENT
Building and Code Enforcement

INSPECTION REQUEST

503-992-3206

Site Address 366 Blue Jay
Contractor John
Phone Number

Scheduled Inspection Date 3-21-06
Mon [] Tues [x] Wed [] Thurs [] Fri []
AM [] PM [] other
Permit Number PLM05-0403

- BUILDING: Footing / Pier, Foundation Wall, Underfloor (P & B), Shear, Framing, Insulation, Approach/Sidewalk, Other, Planning, Final
PLUMBING: Underfloor (P & B), Top Out (Rough), Water Line, Rain/Crawl Drains, Storm Drainage, Sanitary Sewer, Backflow Device, Water Heater, Other, Final
MECHANICAL: Gas Piping, Underfloor (P & B), Rough Mechanical, HVAC (Final), Other
MANUFACTURED HOME: M/H Set-Up, M/H Mechanical, M/H Water/Sewer, M/H Electrical Feeder, M/H Final, Other

Comments:

- [] APPROVED
[x] NOT APPROVED (REINSPECTION REQUIRED)
[] APPROVED AFTER CORRECTIONS (NO REINSPECTION REQUIRED)
[] STOP WORK

CORRECTIONS: Hot water heater to be at operating temp. Hot & cold reversed on master tub

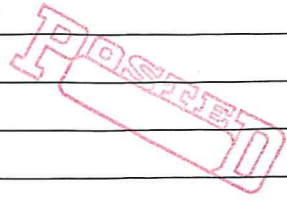

Date: 3-21-06 Inspector: [Signature]



COMMUNITY DEVELOPMENT DEPARTMENT
Building and Code Enforcement

INSPECTION REQUEST

503-992-3206

Site Address 366 BLUEJAY AVENUE
Contractor JOHN
Phone Number 503-522-1523

Scheduled Inspection Date 03/03/06
Mon [] Tues [] Wed [] Thurs [] Fri [x]
AM [] PM [] other
Permit Number PLM05-00103

BUILDING

- Footing / Pier
Foundation Wall
Underfloor (P & B)
Shear
Framing
Insulation
Approach/Sidewalk
Other
Planning
Final

PLUMBING

- Underfloor (P & B)
Top Out (Rough)
Water Line
Rain/Crawl Drains
Storm Drainage
Sanitary Sewer
Backflow Device
Water Heater
Other
Final

MECHANICAL

- Gas Piping
Underfloor (P & B)
Rough Mechanical
HVAC (Final)
Other

MANUFACTURED HOME

- M/H Set-Up
M/H Mechanical
M/H Water/Sewer
M/H Electrical Feeder
M/H Final
Other

Comments:

[] APPROVED

[x] NOT APPROVED
(REINSPECTION REQUIRED)

[] APPROVED AFTER
CORRECTIONS
(NO REINSPECTION REQUIRED)

[] STOP WORK

CORRECTIONS:

- 1 CLEAN-OUT @ REAR YARD TO BE LOWERED TO GRADE LEVEL (AVE C/10'S)
2 COVER EXPOSED STORM DRAINAGE PIPE/FITTINGS
3 HOT/COLD MIXED @ MAIN BATH SHOWER
4 WATER PRESSURE @ HOSE BIBS EXCEEDS 80PSI - P.R.V. WILL BE REQUIRED FOR ALL HOMES IF PRESSURE EXCEEDS 80PSI.
5 STORM DRAIN PIPING TO BE ON FIRM, STABLE GRADE

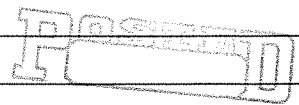

Date: 03/03/06

Inspector: [Signature]



COMMUNITY DEVELOPMENT DEPARTMENT
Building and Code Enforcement

INSPECTION REQUEST

503-992-3206

Site Address 366 BLUEJAY AVENUE
Contractor JOHN
Phone Number 503-522-1573

Scheduled Inspection Date 03/03/06
Mon [] Tues [] Wed [] Thurs [] Fri [x]
AM [] PM [] other
Permit Number MRCOS-00094

BUILDING

PLUMBING

MECHANICAL

MANUFACTURED HOME

- Footing / Pier
Foundation Wall
Underfloor (P & B)
Shear
Framing
Insulation
Approach/Sidewalk
Other
Planning
Final

- Underfloor (P & B)
Top Out (Rough)
Water Line
Rain/Crawl Drains
Storm Drainage
Sanitary Sewer
Backflow Device
Water Heater
Other
Final

- Gas Piping
Underfloor (P & B)
Rough Mechanical
HVAC (Final)
Other

- M/H Set-Up
M/H Mechanical
M/H Water/Sewer
M/H Electrical Feeder
M/H Final
Other

Comments:

[] APPROVED

[x] NOT APPROVED
(REINSPECTION REQUIRED)

[] APPROVED AFTER
CORRECTIONS
(NO REINSPECTION REQUIRED)

[] STOP WORK

CORRECTIONS:

- 1 FLANGE REQUIRED @ CEILING - GARAGE B VENT
2 SEAL AROUND DUCT PENETRATIONS THROUGH GARAGE
CEILING. ALSO GAS PIPING AND ELECTRICAL CONDUIT.
3 FIREPLACE NOT OPERATING
4 SUPPLY AIR GRILLES NOT INSTALLED

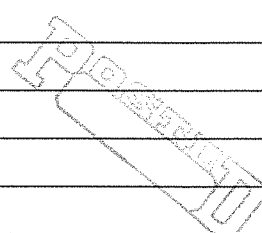

Date: 03/03/06

Inspector: [Signature]



COMMUNITY DEVELOPMENT DEPARTMENT
Building and Code Enforcement

INSPECTION REQUEST

503-992-3206

Site Address 366 Bluejay
Contractor John
Phone Number 503-532-1571

Scheduled Inspection Date 2-14-06
Mon [] Tues [x] Wed [] Thurs [] Fri []
AM [] PM [] other
Permit Number BLD05-00096

BUILDING

PLUMBING

MECHANICAL

MANUFACTURED HOME

- Footing / Pier
Foundation Wall
Underfloor (P & B)
Shear
Framing
Insulation
[X] Approach/Sidewalk
Other
Planning
Final

- Underfloor (P & B)
Top Out (Rough)
Water Line
Rain/Crawl Drains
Storm Drainage
Sanitary Sewer
Backflow Device
Water Heater
Other
Final

- Gas Piping
Underfloor (P & B)
Rough Mechanical
HVAC (Final)
Other

- M/H Set-Up
M/H Mechanical
M/H Water/Sewer
M/H Electrical Feeder
M/H Final
Other

Comments:

- [] APPROVED
[] NOT APPROVED (REINSPECTION REQUIRED)
[X] APPROVED AFTER CORRECTIONS (NO REINSPECTION REQUIRED)
[] STOP WORK

CORRECTIONS: INSTALL 1/2" DOWELS @ 24" OC @ CURB



Date: 2-14-06

Inspector: [Signature]



COMMUNITY DEVELOPMENT DEPARTMENT
Building and Code Enforcement

INSPECTION REQUEST

503-992-3206

Site Address 366 Blue Jay
Contractor Sohn Eagle Cap.
Phone Number 503-357-2490

Scheduled Inspection Date 02-08

Mon [] Tues [] Wed [x] Thurs [] Fri []

AM [x] PM [] other []

Permit Number BLD05-00096

PLM05-00103

BUILDING

- Footing / Pier
Foundation Wall
Underfloor (P & B)
Shear
Framing
Insulation
Approach/Sidewalk
Other
Planning
Final

PLUMBING

- Underfloor (P & B)
Top Out (Rough)
Water Line
Rain/Crawl Drains
Storm Drainage
Sanitary Sewer
Backflow Device
Water Heater
Other
Final

MECHANICAL

- Gas Piping
Underfloor (P & B)
Rough Mechanical
HVAC (Final)
Other

MANUFACTURED HOME

- M/H Set-Up
M/H Mechanical
M/H Water/Sewer
M/H Electrical Feeder
M/H Final
Other

Comments:

[x] APPROVED

[] NOT APPROVED
(REINSPECTION REQUIRED)

[] APPROVED AFTER
CORRECTIONS
(NO REINSPECTION REQUIRED)

[] STOP WORK

CORRECTIONS:

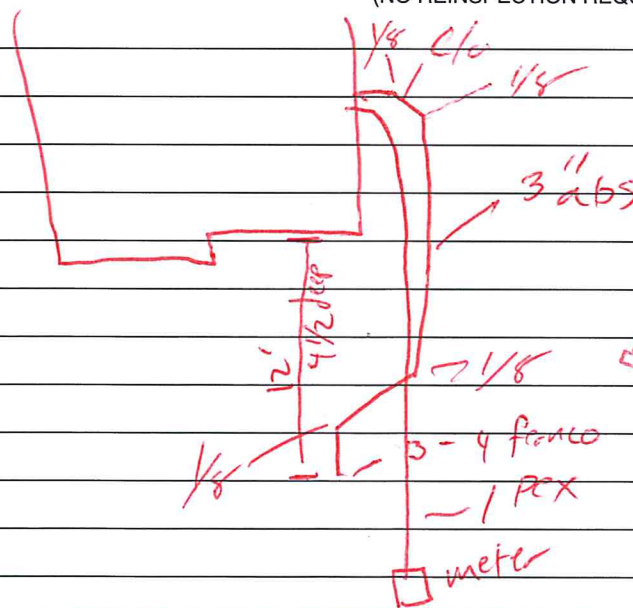

POSTED

Date: 2-8-06

Inspector:

Handwritten signature of the inspector

City of Forest Grove

For Inspection
Call the 24 Hour Inspection Line
(503-992-3206)

PLUMBING PERMIT

PERMIT NO.: PLM06-00068
APPLIED: 3/20/2006
ISSUED: 3/20/2006
EXPIRES: 9/20/2006

SITE ADDRESS: 366 BLUEJAY AVE
ASSESSOR'S PARCEL NO.: 1N435AA-01301
TYPE OF WORK: Alteration
TYPE OF USE: Single Family Residential
PROJECT DESCRIPTION: BACKFLOW FOR IRRIGATION

<p><u>OWNER/APPLICANT</u></p> <p>EAGLE CAP INC 3225 LAVINA FOREST GROVE OR 97116</p>	<p><u>CONTRACTOR</u></p> <p>EAGLE CAP INC 3225 LAVINA FOREST GROVE OR 97116 8253</p>
--	--

Plumbing Fixtures		Fees			
Fixture Type	Quantity	Type	By	Date	Amount
Backflow device	1	PRMT	LVW	3/20/2006	\$27.30
		SUCH	LVW	3/20/2006	\$2.18
Total:					\$29.48

NOTES:

I hereby acknowledge that I have read this permit and state that the above information is correct, and agree to comply with all ordinances and state and federal laws regulating activities covered by this permit.

Issued by _____

Applicant or Owner's Signature

CONDITIONS OF APPROVAL :

1)



Plumbing Permit Application

City of Forest Grove Phone: 503-992-3229 Fax: 503-992-3202
 1924 Council Street/P.O. Box 326, Forest Grove, Oregon 97116 **Inspection Request Line: 503-992-3206**
Permit Number:

TYPE OF WORK	
<input type="checkbox"/> New construction	<input type="checkbox"/> Demolition
<input checked="" type="checkbox"/> Addition/alteration/replacement	<input type="checkbox"/> Other:
CATEGORY OF CONSTRUCTION	
<input checked="" type="checkbox"/> 1- and 2-family dwelling	<input type="checkbox"/> Commercial/industrial
<input type="checkbox"/> Accessory building	<input type="checkbox"/> Multi-family
<input type="checkbox"/> Master builder	<input type="checkbox"/> Other:
JOB SITE INFORMATION AND LOCATION	
Job site address: <u>3606 Blue Jay</u>	
City/State/ZIP: <u>Forest Grove, OR 97114</u>	
Suite/bldg./apt. no.:	Project name: <u>Eagle Cap.</u>
Cross street/directions to job site: <u>Forest Grove Dr.</u>	
Subdivision:	Lot no.:
Tax map/parcel no.:	
DESCRIPTION OF WORK	
Automatic Irrigation system installation	
<input type="checkbox"/> PROPERTY OWNER	<input type="checkbox"/> TENANT
Name: <u>Eagle Cap, Inc.</u>	
Address:	
City/State/ZIP: <u>Forest Grove, OR 97110</u>	
Phone: ()	Fax: ()
<input checked="" type="checkbox"/> APPLICANT	<input type="checkbox"/> CONTACT PERSON
Business name: <u>Forest Landscape, Inc.</u>	
Contact name: <u>Vanessa</u>	
Address: <u>40437 NW Verboort Rd.</u>	
City/State/ZIP: <u>Forest Grove, OR 97116</u>	
Phone: <u>(503) 357-3808</u>	Fax: <u>(503) 359-1908</u>
E-mail:	
CONTRACTOR	
Business name: <u>Forest Landscape, Inc.</u>	
Address: <u>40437 NW Verboort Rd</u>	
City/State/ZIP: <u>Forest Grove, OR 97116</u>	
Phone: <u>(503) 357-3808</u>	Fax: <u>(503) 359-1908</u>
CCB lic.: <u>LCB 8253</u>	Lic. no.:

FEE* SCHEDULE			
<i>For special information use checklist.</i>			
Description	Qty.	Ea.	Total
New 1- 2-family dwellings (includes 100 ft. for each utility connection)			
SFR (1) bath		239.50	
SFR (2) bath		316.75	
SFR (3) bath		386.25	
Each additional bath/kitchen		41.72	
Fire sprinkler (____ sq. ft.)		By sq ft	
Site utilities			
Catch basin or area drain		13.90	
Drywell, leach line, or trench drain		13.90	
Footing drain (no. linear ft.: ____)		46.35	
Manufactured home utilities			
Manholes		13.90	
Rain drain connector		13.90	
Sanitary sewer (each 100 ft.: ____)		46.35	
Storm sewer (each 100 ft.: ____)		46.35	
Water service (each 100 ft.: ____)		46.35	
Fixture or item			
Absorption valve		13.90	
Backflow preventer	1	13.90	13.90
Backwater valve		13.90	
Clothes washer		13.90	
Dishwasher		13.90	
Drinking fountain		13.90	
Ejectors/sump		13.90	
Expansion tank		13.90	
Fixture/sewer cap		13.90	
Floor drain/floor sink/hub		13.90	
Garbage disposal		13.90	
Hose bib		13.90	
Ice maker		13.90	
Interceptor/grease trap		13.90	
Medical gas (value: \$ ____)		By value	
Primer		13.90	
Roof drain (commercial)		13.90	
Sink/basin/lavatory		13.90	
Tub/shower/shower pan		13.90	
Urinal		13.90	
Water closet		13.90	
Water heater		13.90	
Other:		13.90	
Other:			
Subtotal			13.90
Minimum permit fee			\$27.30
Plan review (____ % of permit fee)			
State surcharge (8% of permit fee)			
TOTAL PERMIT FEE			29.48

This permit application expires if a permit is not obtained within 180 days after it has been accepted as complete.

* Fee methodology set by Tri-County Building Industry Service Board
440-4616T (10/02/COM/WEB)

Authorized signature:

Print name: Vanessa Castaneda Date: 3/20/08



COMMUNITY DEVELOPMENT DEPARTMENT
Building and Code Enforcement
INSPECTION REQUEST
 503-992-3206

Site Address 366 Blue Jay
 Contractor _____
 Phone Number _____

Scheduled Inspection Date 1-12-06
 Mon Tues Wed Thurs Fri
 AM PM other _____
 Permit Number PLM05-00103

BUILDING

- Footing / Pier
- Foundation Wall
- Underfloor (P & B)
- Shear
- Framing
- Insulation
- Approach/Sidewalk
- Other
- Planning
- Final

PLUMBING

- Underfloor (P & B)
- Top Out (Rough)
- Water Line
- Rain/Crawl Drains
- Storm Drainage
- Sanitary Sewer
- Backflow Device
- Water Heater
- Other
- Final

MECHANICAL

- Gas Piping
- Underfloor (P & B)
- Rough Mechanical
- HVAC (Final)
- Other

MANUFACTURED HOME

- M/H Set-Up
- M/H Mechanical
- M/H Water/Sewer
- M/H Electrical Feeder
- M/H Final
- Other

Comments: _____

APPROVED

NOT APPROVED
 (REINSPECTION REQUIRED)

APPROVED AFTER
 CORRECTIONS
 (NO REINSPECTION REQUIRED)

STOP WORK

CORRECTIONS: _____

Blue Jay

3-4 feet deep storm

POSTED

Date: 1-12-06 Inspector: [Signature]



EAGLE CAP, QNC.

357-2490

3225 Lavina, Forest Grove, Oregon 97116



To: Dennis Carne
Building Official

It is my understanding that a development agreement between the City of Forest Grove and Eagle Cap has been signed. Also a performance set aside agreement guaranteeing that the subdivision with all utilities will be completed has been established.

I am requesting that permits for models on property tax lot of record (1300 & 1301) be issued, at Holscher farm subdivision. As an additional precaution house siting will be done under the supervision of a licensed surveyor.

Eagle Cap holds the city of Forest Grove, its elected & appointed officials, its officers, agents, employees and volunteers harmless for any problems, expenses and liability arising as a result of this model construction.

Sincerely,

John Crosley
Pres.



COMMUNITY DEVELOPMENT DEPARTMENT
Building and Code Enforcement

INSPECTION REQUEST

503-992-3206

Site Address 366 Blue Jay
Contractor Jim
Phone Number 781-0576

Scheduled Inspection Date 8-19-05
Mon [] Tues [] Wed [] Thurs [] Fri [X]
AM [X] PM [] other
Permit Number BLD05-00096

- BUILDING
[X] Footing / Pier
[X] Foundation Wall
Underfloor (P & B)
Shear
Framing
Insulation
Approach/Sidewalk
Other
Planning
Final

- PLUMBING
Underfloor (P & B)
Top Out (Rough)
Water Line
Rain/Crawl Drains
Storm Drainage
Sanitary Sewer
Backflow Device
Water Heater
Other
Final

- MECHANICAL
Gas Piping
Underfloor (P & B)
Rough Mechanical
HVAC (Final)
Other

- MANUFACTURED HOME
M/H Set-Up
M/H Mechanical
M/H Water/Sewer
M/H Electrical Feeder
M/H Final
Other

Comments:

- [X] APPROVED
[] NOT APPROVED (REINSPECTION REQUIRED)
[] APPROVED AFTER CORRECTIONS (NO REINSPECTION REQUIRED)
[] STOP WORK

CORRECTIONS:

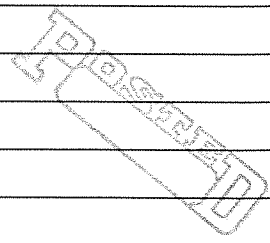

Date: 8-19-05 Inspector: [Signature]



COMMUNITY DEVELOPMENT DEPARTMENT
Building and Code Enforcement

INSPECTION REQUEST

503-992-3206

Site Address 366 Bluejay Ave
Contractor John
Phone Number

Scheduled Inspection Date 8-26-05
Mon [] Tues [] Wed [] Thurs [] Fri [x]
AM [x] PM [] other
Permit Number BUD05-00096

BUILDING

PLUMBING

MECHANICAL

MANUFACTURED HOME

- Footing / Pier
Foundation Wall
[x] Underfloor (P & B)
Shear
Framing
Insulation
Approach/Sidewalk
Other
Planning
Final

- Underfloor (P & B)
Top Out (Rough)
Water Line
Rain/Crawl Drains
Storm Drainage
Sanitary Sewer
Backflow Device
Water Heater
Other
Final

- Gas Piping
Underfloor (P & B)
Rough Mechanical
HVAC (Final)
Other

- M/H Set-Up
M/H Mechanical
M/H Water/Sewer
M/H Electrical Feeder
M/H Final
Other

Comments:

[] APPROVED

[x] NOT APPROVED
(REINSPECTION REQUIRED)

[] APPROVED AFTER
CORRECTIONS
(NO REINSPECTION REQUIRED)

[] STOP WORK

CORRECTIONS:

* Provide lateral bracing on posts over 4'

NOTE: Mech not underfloor @ this insp.

POSTED

Date:

Inspector:



COMMUNITY DEVELOPMENT DEPARTMENT
Building and Code Enforcement

INSPECTION REQUEST

503-992-3206

Site Address 366 Bluejay Ave
Contractor John
Phone Number

Scheduled Inspection Date 8-26-05
Mon [] Tues [] Wed [] Thurs [] Fri [x]
AM [x] PM [] other
Permit Number PUM05-00103

BUILDING

- Footing / Pier
Foundation Wall
Underfloor (P & B)
Shear
Framing
Insulation
Approach/Sidewalk
Other
Planning
Final

PLUMBING

- [x] Underfloor (P & B)
Top Out (Rough)
Water Line
[x] Rain/Crawl Drains
Storm Drainage
Sanitary Sewer
Backflow Device
Water Heater
Other
Final

MECHANICAL

- Gas Piping
Underfloor (P & B)
Rough Mechanical
HVAC (Final)
Other

MANUFACTURED HOME

- M/H Set-Up
M/H Mechanical
M/H Water/Sewer
M/H Electrical Feeder
M/H Final
Other

Comments:

[] APPROVED

[x] NOT APPROVED
(REINSPECTION REQUIRED)

[] APPROVED AFTER
CORRECTIONS

(NO REINSPECTION REQUIRED)

[] STOP WORK

CORRECTIONS:

* No water piping under floor

* Provide proper directional fittings on south end rain drains

* Strap raindrains to ftgs.

POSTED

Date:

8/26/05

Inspector:

[Signature]

City of Forest Grove

For Inspections
Call the 24 Hour Inspection Line
(503-992-3206)

BUILDING PERMIT

PERMIT NO.: BLD05-00096
APPLIED: 4/29/2005
ISSUED: 7/29/2005
EXPIRES: 1/29/2006

SITE ADDRESS: 366 BLUEJAY AVE

ASSESSOR'S PARCEL NO.: 1N435AA-01301

PROJECT DESCRIPTION: NEW SFR/LOT # 4/HOLSCHER
FARMS/PLAN # M-2751A/ 2 FLOORS/ 4 BED/

<u>OWNER/APPLICANT</u>	<u>CONTRACTOR</u> EAGLE CAP INC 3225 LAVINA FOREST GROVE OR 97116 62811
------------------------	---

TYPE OF WORK: NEW	AREA	VALUE: \$247,894.80
TYPE OF USE: SF	LOT: 0sf	REQUIRED SETBACKS:
CENSUS CATEGORY:	1ST FLR: 0sf	FRONT: 22.00 ft
ZONING:	2ND FLR: 0sf	SIDE 1: 8 ft
Occupancy Groups	BASEMENT: 0sf	SIDE 2: 8 ft
1: 2:	GAR/CARPORT: 0sf	REAR: 31 ft
3: 4:	OTHER: 0sf	REQUIRED PARKING
Construction Types	NUMBER OF UNITS: 0	TOTAL: 4
1: 2:	STORIES: 0	HANDICAPPED: 0
3: 4:	BUILDING HEIGHT: 0 ft	COMPACT: 0
		IMPRV SURF: 0 sf

FEES			
Type	By	Date	Amount
PRMT	MLP	7/29/2005	\$1,677.05
SUCH	MLP	7/29/2005	\$134.16
PLAN	MLP	4/29/2005	\$1,090.08
SITE	MLP	7/29/2005	\$235.00
EXCA	MLP	7/29/2005	\$22.00
(additional fees not shown here)			Total: \$13,768.29

NOTES:

I hereby acknowledge that I have read this permit and state that the above information is correct, and agree to comply with all ordinances and state and federal laws regulating activities covered by this permit.

Issued by _____

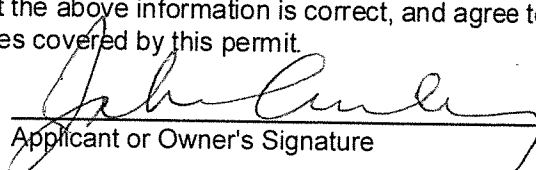
Applicant or Owner's Signature

CONDITIONS OF APPROVAL:

1 approved on condition of final subdivision approval per engineering

City of Forest Grove

For Inspections
Call the 24 Hour Inspection Line
(503-992-3206)

BUILDING PERMIT

PERMIT NO.: BLD05-00096
APPLIED: 4/29/2005
ISSUED: 7/29/2005
EXPIRES: 1/29/2006

- 2 INSTALL CONSTRUCTION ACCESS - 8" MINIMUM DEPTH BASE ROCK PAD, 20' MINIMUM LENGTH AND W
DO NOT TRACK MUD ONTO STREETS
- 3 INSTALL EROSION CONTROL FENCING AS REQUIRED PER CLEAN WATER SERVICES STANDARD
SPECIFICATIONS.
- 4 PIPE ALL ROOF WATER THROUGH 3" MINIMUM DIAMETER PIPE PER UNIFORM PLUMBING CODE AND
THROUGH CURB WEEP HOLES TO STREET PER CITY STANDARD SPECIFICATIONS.
- 5 INSTALL CONCRETE SIDEWALK AND DRIVE APPROACH PER CITY STANDARD SPECIFICATIONS.
- 6 THE STREET ADDRESS SHALL BE DISPLAYED IN A PROMINENT POSITION NEAR THE ENTRANCE TO TH
BUILDING. NUMBERS SHALL BE AT LEAST 4 INCHES HIGH, OF A CONTRASTING COLOR AND VISIBLE F
THE STREET. MUNICIPAL CODE SECTION 9.215
- 7 ONE STREET TREE TO BE PLANTED IN PARKWAY. INSTALLATION TO BE COMPLETED BY THE CITY.
- 8 NOT FOR CONSTRUCTION - this a preliminary review only by L&P Dept. No electrical power is available to
lot at this time. Building contractor is required to contact the Light & Power Dept. for final approval/review
plans, after the electrical backbone system has been installed for the subdivision. Electrical service will not
provided until final approval of plans...

24 Hour Notice Required For All Inspections

City of Forest Grove

For Inspection
Call the 24 Hour Inspection Line
(503-992-3206)

PLUMBING PERMIT

PERMIT NO.: **PLM05-00103**
APPLIED: **4/29/2005**
ISSUED: **7/29/2005**
EXPIRES: **1/29/2006**

SITE ADDRESS: **366 BLUEJAY AVE**
ASSESSOR'S PARCEL NO.: **1N435AA-01301**
TYPE OF WORK: **New**
TYPE OF USE: **Single Family Residential**
PROJECT DESCRIPTION: **NEW SFR/LOT # 4/HOLSCHER FARMS/PLAN #
M-2751A/ 2 FLOORS/ 4 BED/ 3 BATH/ 2 CAR**

<u>OWNER/APPLICANT</u> EAGLE CAP INC 3225 LAVINA FOREST GROVE OR 97116	<u>CONTRACTOR</u> EAGLE CAP INC 3225 LAVINA FOREST GROVE OR 97116 62811
---	---

Plumbing Fixtures		Fees			
Fixture Type	Quantity	Type	By	Date	Amount
		BTH1	MGM	7/29/2005	\$386.25
		SUCH	MGM	7/29/2005	\$30.90
Total:					\$417.15

NOTES:

I hereby acknowledge that I have read this permit and state that the above information is correct, and agree to comply with all ordinances and state and federal laws regulating activities covered by this permit.

Issued by _____

 Applicant or Owner's Signature

CONDITIONS OF APPROVAL :

1)

City of Forest Grove

For Inspections
Call the 24 Hour Inspection Line
(503-992-3206)

MECHANICAL PERMIT

PERMIT NO.: MEC05-00094
ISSUED: 7/29/2005
APPLIED: 4/29/2005
EXPIRES: 1/29/2006

SITE ADDRESS: 366 BLUEJAY AVE
ASSESSOR'S PARCEL NO.: 1N435AA-01301
TYPE OF WORK: NEW
TYPE OF USE: SFD
PROJECT DESCRIPTION: NEW SFR/LOT # 4/HOLSCHER FARMS/PLAN # M-2751A/ 2
FLOORS/ 4 BED/ 3 BATH/ 2 CAR GARAGE

<p><u>OWNER/APPLICANT</u></p> <p>EAGLE CAP INC 3225 LAVINA FOREST GROVE OR 97116</p>	<p><u>CONTRACTOR</u></p> <p>EAGLE CAP INC 3225 LAVINA FOREST GROVE OR 97116 62811</p>
--	---

Equipment	
Type of Equipment	Quantity
Air Conditioner	1.00
Clothes Dryers	1.00
Exhaust Hoods	1.00
Fireplace	1.00
Gas Outlets	4.00
Furnaces Under 100,000	1.00
Ventilation Fans	4.00
Water Heater Vent	1.00

Fees			
Type	By	Date	Amount
PRMT	MGM	7/29/2005	\$84.65
SUCH	MGM	7/29/2005	\$6.77
Total:			\$91.42

NOTES:

I hereby acknowledge that I have read this permit and state that the above information is correct, and agree to comply with all ordinances and state and federal laws regulating activities covered by this permit.

Issued By: _____

Applicant or Owner's Signature

24 Hour Notice Required For All Inspections

CONDITIONS OF APPROVAL:

city of
forest
grove

City of Forest Grove

1924 Council Street/P.O. Box 326, Forest Grove, OR 97116

Permit Number:

Building Permit Application

Phone: 503-992-3229

Fax: 503-992-3202

Inspection Request Line: 503-992-3206

BLDOS - 00096

TYPE OF WORK	
<input checked="" type="checkbox"/> New construction	<input type="checkbox"/> Demolition
<input type="checkbox"/> Addition/alteration/replacement	<input type="checkbox"/> Other:
CATEGORY OF CONSTRUCTION	
<input checked="" type="checkbox"/> 1- and 2-family dwelling	<input type="checkbox"/> Commercial/industrial
<input type="checkbox"/> Accessory building	<input type="checkbox"/> Multi-family
<input type="checkbox"/> Master builder	<input type="checkbox"/> Other:
JOB SITE INFORMATION AND LOCATION	
Job site address: 366 Bluejay AV	
City/State/ZIP: Forest Grove OR 97116	
Suite/bldg./apt. no.:	Project name:
Cross street/directions to job site:	
Subdivision: Holscher farm Lot no.: 4	
Tax map/parcel no.: IN 4 35AA 1301	
DESCRIPTION OF WORK	
Construct single family dwelling	
<input type="checkbox"/> PROPERTY OWNER	<input type="checkbox"/> TENANT
Name:	
Address:	
City/State/ZIP:	
Phone: ()	Fax: ()
<input checked="" type="checkbox"/> APPLICANT	<input type="checkbox"/> CONTACT PERSON
Business name: Eagle Cap Inc.	
Contact name: John Crosley	
Address: 3225 Lavina	
City/State/ZIP: Forest Grove OR 97116	
Phone: (503) 357-2490	Fax: (503) 357-2490
E-mail:	
CONTRACTOR	
Business name: Eagle Cap Inc	
Address: 3225 Lavina	
City/State/ZIP: Forest Grove OR 97116	
Phone: (503) 357-2490	Fax: ()
CCB lic.: 62811	

Authorized signature: *John Crosley*
 Print name: John Crosley Date: 4/1/05

REQUIRED DATA: 1- AND 2-FAMILY DWELLING
 Permit fees* are based on the value of the work performed. Indicate the value (rounded to the nearest dollar) of all equipment, materials, labor, overhead, and the profit for the work indicated on this application.

Valuation

Number of bedrooms: 4
 Number of bathrooms: 2 1/2
 Total number of floors: 2
 New dwelling area: square feet 2555
 Garage/carport area: 420 square feet
 Covered porch area: 60 square feet
 Deck area: square feet
 Other structure area: square feet

REQUIRED DATA: COMMERCIAL-USE CHECKLIST
 Permit fees* are based on the value of the work performed. Indicate the value (rounded to the nearest dollar) of all equipment, materials, labor, overhead, and the profit for the work indicated on this application.

Valuation

Existing building area: square feet
 New building area: square feet
 Number of stories:
 Type of construction:
 Occupancy groups:
 Existing:
 New:

NOTICE
 All contractors and subcontractors are required to be licensed with the Oregon Construction Contractors Board under ORS 701 and may be required to be licensed in the jurisdiction in which work is being performed. If the applicant is exempt from licensing, the following reasons apply:

BUILDING PERMIT FEES*
 Please refer to fee schedule

Fees due upon application	
Amount received	
Date received:	

John
 7-28-05
BUILDING
 Industry Service Board



Plumbing Permit Application

City of Forest Grove

Phone: 503-992-3229

Fax: 503-992-3202

1924 Council Street/P.O. Box 326, Forest Grove, Oregon 97116

Inspection Request Line: 503-992-3206

Permit Number:

PLM05-00103 2 1/2 bath

TYPE OF WORK	
<input checked="" type="checkbox"/> New construction	<input type="checkbox"/> Demolition
<input type="checkbox"/> Addition/alteration/replacement	<input type="checkbox"/> Other:
CATEGORY OF CONSTRUCTION	
<input checked="" type="checkbox"/> 1- and 2-family dwelling	<input type="checkbox"/> Commercial/industrial
<input type="checkbox"/> Accessory building	<input type="checkbox"/> Multi-family
<input type="checkbox"/> Master builder	<input type="checkbox"/> Other:
JOB SITE INFORMATION AND LOCATION	
Job site address: <u>Bluejay AV</u>	
City/State/ZIP: <u>Forest Grove OR 97126</u>	
Suite/bldg./apt. no.:	Project name:
Cross street/directions to job site:	
Subdivision: <u>Holscher farm</u> Lot no.: <u>4</u>	
Tax map/parcel no.: <u>1N4 35AA 130 1</u>	
DESCRIPTION OF WORK	
<input type="checkbox"/> PROPERTY OWNER <input type="checkbox"/> TENANT	
Name:	
Address:	
City/State/ZIP:	
Phone: ()	Fax: ()
<input type="checkbox"/> APPLICANT	<input type="checkbox"/> CONTACT PERSON
Business name:	
Contact name:	
Address:	
City/State/ZIP:	
Phone: ()	Fax: ()
E-mail:	
CONTRACTOR	
Business name: <u>Jerry Brown Plumbing</u>	
Address: <u>4357B NW Purdin Rd</u>	
City/State/ZIP: <u>FG OR 97116</u>	
Phone: <u>(503) 357-3600</u>	Fax: ()
CCB lic.: <u>150256</u>	PB Lic. no.:

FEE* SCHEDULE			
For special information use checklist.			
Description	Qty.	Ea.	Total
New 1- 2-family dwellings (includes 100 ft. for each utility connection)			
SFR (1) bath		239.50	
SFR (2) bath		316.75	
SFR (3) bath		386.25	
Each additional bath/kitchen		41.72	
Fire sprinkler (____ sq. ft.)		46.35	
Site utilities			
Catch basin or area drain		13.90	
Drywell, leach line, or trench drain		13.90	
Footing drain (no. linear ft.: ____)		46.35	
Manufactured home utilities			
Manholes		13.90	
Rain drain connector		13.90	
Sanitary sewer (no. linear ft.: ____)		46.35	
Storm sewer (no. linear ft.: ____)		46.35	
Water service (no. linear ft.: ____)		46.35	
Fixture or item			
Absorption valve		13.90	
Backflow preventer		13.90	
Backwater valve		13.90	
Clothes washer		13.90	
Dishwasher		13.90	
Drinking fountain		13.90	
Ejectors/sump		13.90	
Expansion tank		13.90	
Fixture/sewer cap		13.90	
Floor drain/floor sink/hub		13.90	
Garbage disposal		13.90	
Hose bib		13.90	
Ice maker		13.90	
Interceptor/grease trap		13.90	
Medical gas (value: \$ ____)			
Primer		13.90	
Roof drain (commercial)		13.90	
Sink/basin/lavatory		13.90	
Tub/shower/shower pan		13.90	
Urinal		13.90	
Water closet		13.90	
Water heater		13.90	
Other:		13.90	
Other:			
Subtotal			
Minimum permit fee			\$ 27.30
Plan review (____% of permit fee)			
State surcharge (8% of permit fee)			
TOTAL PERMIT FEE			

Authorized signature:

Print name: John Crosby

Date: 4/29/05

This permit application expires if a permit is not obtained within 180 days after it has been accepted as complete.

* Fee methodology set by Tri-County Building Industry Service Board 440-4616T (10/02/COM/WEB)



TYPE OF WORK

New construction Addition/alteration/replacement
 Demolition Other:

CATEGORY OF CONSTRUCTION

1- and 2-family dwelling Commercial/industrial Accessory building
 Multi-family Master builder Other:

JOB SITE INFORMATION AND LOCATION

Job site address: Bluejay AV
 City/State/ZIP: Forest Grove OR 97116
 Suite/bldg./apt. no.: _____ Project name: _____
 Cross street/directions to job site: _____

Subdivision: Holscher Farm Lot no.: 4
 Tax map/parcel no.: IN 4 35 AA 1301

DESCRIPTION OF WORK

PROPERTY OWNER **TENANT**

Name: EAGLE CAP INC
 Address: _____
 City/State/ZIP: _____
 Phone: () _____ Fax: () _____

APPLICANT **CONTACT PERSON**

Business name: EAGLE CAP INC
 Contact name: John Crosley
 Address: 3225 LAVINA
 City/State/ZIP: Forest Grove OR 97116
 Phone: (503) 357-2490 Fax: (503) 357-2490
 E-mail: _____

CONTRACTOR

Business name: ~~EAGLE CAP INC~~ Swanson Heating
 Address: Bx 441
 City/State/ZIP: Corv. OR 97113
 Phone: (503) 357-5098 Fax: () _____
 CCB lic.: 50744

Authorized signature: John Crosley
 Print name: John Crosley Date: 4/29/05

COMMERCIAL FEE* SCHEDULE - USE CHECKLIST

Mechanical permit fees* are based on the value of the work performed. Indicate the value (rounded to the nearest dollar) of all mechanical materials, equipment, labor, overhead, and profit.
 Value: \$ _____

RESIDENTIAL EQUIPMENT / SYSTEMS FEES*

For special information use checklist.

Description	Qty.	Ea.	Total
Heating/cooling			
Furnace add-on air conditioning	1	11.90	
Gas heat pump	1	8.95	
Duct work		15.85	
Hydronic hot water system			
Residential boiler (radiator or hydronic)		11.90	
Unit heaters (fuel-type, not electric), in-wall, in-duct, suspended, etc.		11.90	
Flue/vent for any of above		6.00	
Other:		8.95	

Other fuel appliances

Water heater	1	8.95	
Gas fireplace	1	8.95	
Flue vent for water heater or gas fireplace		6.00	
Log lighter (gas)		8.95	
Wood/pellet stove		8.95	
Wood fireplace/insert		8.95	
Chimney/liner/flue/vent		6.00	
Other:		8.95	

Environmental exhaust and ventilation

Range hood/other kitchen equipment	1	8.95	
Clothes dryer exhaust	1	8.95	
Single-duct exhaust (bathrooms, toilet compartments, utility rooms)	4	6.00	
Attic/crawl space fans		6.00	
Other:		8.95	

Fuel piping

\$4.00 for first four outlets; \$1.05 for each additional

Furnace, etc.	1	By Outlet #	
Gas heat pump		By Outlet #	
Wall/suspended/unit heater		By Outlet #	
Water heater	1	By Outlet #	
Fireplace	1	By Outlet #	
Range	1	By Outlet #	
Barbecue		By Outlet #	
Clothes dryer (gas)		By Outlet #	
Other:			

MECHANICAL PERMIT FEES*

Subtotal	
Minimum permit fee	27.30
Plan review (% of permit fee)	
State surcharge (8% of permit fee)	
TOTAL PERMIT FEE	

This permit application expires if a permit is not obtained within 180 days after it has been accepted as complete.

* Fee methodology set by Tri-County Building Industry Service Board
 440-4617T (11/02/COM/WEB)



COMMUNITY DEVELOPMENT DEPARTMENT
Building and Code Enforcement

INSPECTION REQUEST

503-992-3206

Site Address 366 Bluejay
Contractor John
Phone Number

Scheduled Inspection Date 8-30-05
Mon [] Tues [x] Wed [] Thurs [] Fri []
AM [] PM [] other
Permit Number NE-005-0009

BUILDING

- Footing / Pier
Foundation Wall
Underfloor (P & B)
Shear
Framing
Insulation
Approach/Sidewalk
Other
Planning
Final

PLUMBING

- Underfloor (P & B)
Top Out (Rough)
Water Line
Rain/Crawl Drains
Storm Drainage
Sanitary Sewer
Backflow Device
Water Heater
Other
Final

MECHANICAL

- Gas Piping
Underfloor (P & B)
Rough Mechanical
HVAC (Final)
Other

MANUFACTURED HOME

- M/H Set-Up
M/H Mechanical
M/H Water/Sewer
M/H Electrical Feeder
M/H Final
Other

Comments:

[x] APPROVED

[] NOT APPROVED
(REINSPECTION REQUIRED)

[] APPROVED AFTER
CORRECTIONS
(NO REINSPECTION REQUIRED)

[] STOP WORK

CORRECTIONS:

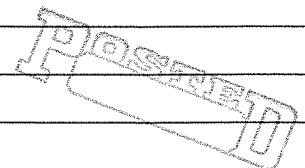

Date: 8-30-05

Inspector:

[Signature]



COMMUNITY DEVELOPMENT DEPARTMENT
Building and Code Enforcement

INSPECTION REQUEST

503-992-3206

Site Address 366 Bluejay
Contractor John
Phone Number

Scheduled Inspection Date 8/30/05
Mon [] Tues [x] Wed [] Thurs [] Fri []
AM [] PM [] other
Permit Number 00096

BUILDING

- Footing / Pier
Foundation Wall
Underfloor (P & B)
Shear
Framing
Insulation
Approach/Sidewalk
Other
Planning
Final

PLUMBING

- Underfloor (P & B)
Top Out (Rough)
Water Line
Rain/Crawl Drains
Storm Drainage
Sanitary Sewer
Backflow Device
Water Heater
Other
Final

MECHANICAL

- Gas Piping
Underfloor (P & B)
Rough Mechanical
HVAC (Final)
Other

MANUFACTURED HOME

- M/H Set-Up
M/H Mechanical
M/H Water/Sewer
M/H Electrical Feeder
M/H Final
Other

Comments:

[] APPROVED

[x] NOT APPROVED
(REINSPECTION REQUIRED)

[] APPROVED AFTER
CORRECTIONS

(NO REINSPECTION REQUIRED)

[] STOP WORK

CORRECTIONS: 1 Fix Upper Barrier south side
2 Remove construction debris from crawl space
3 min two bdts on pt in Entry

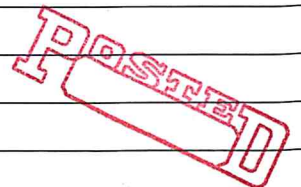

Date: 8-30-05

Inspector: [Signature]



COMMUNITY DEVELOPMENT DEPARTMENT
Building and Code Enforcement

INSPECTION REQUEST

503-992-3206

Site Address 366 Bluejay

Contractor

Phone Number

Scheduled Inspection Date 10/18/05

Mon [] Tues [x] Wed [] Thurs [] Fri []

AM [] PM [] other

Permit Number 00096

- BUILDING: Footing / Pier, Foundation Wall, Underfloor (P & B), Shear, Framing (checked), Insulation, Approach/Sidewalk, Other, Planning, Final
PLUMBING: Underfloor (P & B), Top Out (Rough), Water Line, Rain/Crawl Drains, Storm Drainage, Sanitary Sewer, Backflow Device, Water Heater, Other, Final
MECHANICAL: Gas Piping, Underfloor (P & B), Rough Mechanical, HVAC (Final), Other
MANUFACTURED HOME: M/H Set-Up, M/H Mechanical, M/H Water/Sewer, M/H Electrical Feeder, M/H Final, Other
Comments:

[] APPROVED [x] NOT APPROVED (REINSPECTION REQUIRED) [] APPROVED AFTER CORRECTIONS (NO REINSPECTION REQUIRED) [] STOP WORK

CORRECTIONS: 1) PROVIDE ENG. Fix For Cut TJI Below tub in Garage 2) PROVIDE Mechanical attachment from glue lams to cut top plates in garage 3) PROVIDE ENG. fix for cut TJI Above Laundry 4) PROVIDE Mechanical connection from header to plates @ Dining room window 5) PROVIDE ENG. FOR TRUSS "A" + B Design change 6) PROVIDE STRAPS @ window mullions on TALL Back wall 7) complete under stair access

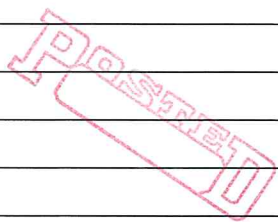

Date: 10.18.05

Inspector: AWL



COMMUNITY DEVELOPMENT DEPARTMENT
Building and Code Enforcement

INSPECTION REQUEST

503-992-3206

Site Address 306 Bluejay
Contractor
Phone Number

Scheduled Inspection Date 10/18/05
Mon [] Tues [x] Wed [] Thurs [] Fri []
AM [] PM [] other
Permit Number 00094

- BUILDING
Footing / Pier
Foundation Wall
Underfloor (P & B)
Shear
Framing
Insulation
Approach/Sidewalk
Other
Planning
Final

- PLUMBING
Underfloor (P & B)
Top Out (Rough)
Water Line
Rain/Crawl Drains
Storm Drainage
Sanitary Sewer
Backflow Device
Water Heater
Other
Final

- MECHANICAL
Gas Piping
Underfloor (P & B)
Rough Mechanical
HVAC (Final)
Other

- MANUFACTURED HOME
M/H Set-Up
M/H Mechanical
M/H Water/Sewer
M/H Electrical Feeder
M/H Final
Other

Comments:

- [] APPROVED
[] NOT APPROVED (REINSPECTION REQUIRED)
[] APPROVED AFTER CORRECTIONS (NO REINSPECTION REQUIRED)
[] STOP WORK

CORRECTIONS: 1 connect Bath Fans Down stairs 2 PROVIDE Permanent attachment (DUCT TAPE) FOR upstairs fans
3 complete Gas line to Fire place

[Red scribbled signature]

POSTED

Date: 10-18-05

Inspector: [Signature]



COMMUNITY DEVELOPMENT DEPARTMENT
Building and Code Enforcement

INSPECTION REQUEST

503-992-3206

Site Address 366 Blue Jay
Contractor
Phone Number

Scheduled Inspection Date 10/18/05
Mon [] Tues [x] Wed [] Thurs [] Fri []
AM [] PM [] other
Permit Number PLMOS-0903

BUILDING

PLUMBING

MECHANICAL

MANUFACTURED HOME

- Footing / Pier
Foundation Wall
Underfloor (P & B)
Shear
Framing
Insulation
Approach/Sidewalk
Other
Planning
Final

- Underfloor (P & B)
[x] Top Out (Rough)
Water Line
Rain/Crawl Drains
Storm Drainage
Sanitary Sewer
Backflow Device
Water Heater
Other
Final

- Gas Piping
Underfloor (P & B)
Rough Mechanical
HVAC (Final)
Other

- M/H Set-Up
M/H Mechanical
M/H Water/Sewer
M/H Electrical Feeder
M/H Final
Other

Comments:

[] APPROVED

[] NOT APPROVED
(REINSPECTION REQUIRED)

[x] APPROVED AFTER
CORRECTIONS
(NO REINSPECTION REQUIRED)

[] STOP WORK

CORRECTIONS NOTE: THERE IS A PIN-HOLE LEAK
IN 1/2" PEX PIPE @ HALLWAY BATHUB/
SHOWER @ 2ND FLOOR. IT IS ON SUPPLY
LINE.

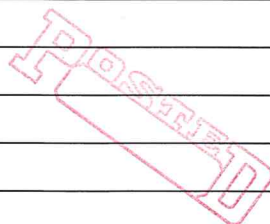

Date: 10/18/05

Inspector: [Signature]



COMMUNITY DEVELOPMENT DEPARTMENT
Building and Code Enforcement

INSPECTION REQUEST

503-992-3206

Site Address 366 BLUEJAY AVENUE
Contractor JOHN
Phone Number 503/522/1571

Scheduled Inspection Date 10/05/05
Mon [] Tues [] Wed [x] Thurs [] Fri []
AM [] PM [] other []
Permit Number BLD05-00096

BUILDING

- Footing / Pier
Foundation Wall
Underfloor (P & B)
[X] Shear
Framing
Insulation
Approach/Sidewalk
Other
Planning
Final

PLUMBING

- Underfloor (P & B)
Top Out (Rough)
Water Line
Rain/Crawl Drains
Storm Drainage
Sanitary Sewer
Backflow Device
Water Heater
Other
Final

MECHANICAL

- Gas Piping
Underfloor (P & B)
Rough Mechanical
HVAC (Final)
Other

MANUFACTURED HOME

- M/H Set-Up
M/H Mechanical
M/H Water/Sewer
M/H Electrical Feeder
M/H Final
Other

Comments:
[]

- [x] APPROVED
[] NOT APPROVED (REINSPECTION REQUIRED)
[] APPROVED AFTER CORRECTIONS (NO REINSPECTION REQUIRED)
[] STOP WORK

CORRECTIONS:
[]

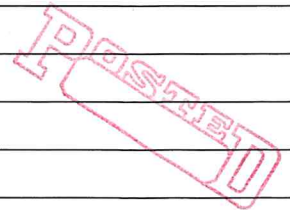

Date: 10-5-5 Inspector: [Signature]



COMMUNITY DEVELOPMENT DEPARTMENT
Building and Code Enforcement

INSPECTION REQUEST

503-992-3206

Site Address 366 Blue Jay Ave
Contractor John
Phone Number 503-522-1571

Scheduled Inspection Date 8-31-05
Mon [] Tues [] Wed [x] Thurs [] Fri []
AM [x] PM [] other early
Permit Number 00096

- BUILDING
Footing / Pier
Foundation Wall
Underfloor (P & B)
Shear
Framing
Insulation Underfloor
Approach/Sidewalk
Other
Planning
Final

- PLUMBING
Underfloor (P & B)
Top Out (Rough)
Water Line
Rain/Crawl Drains
Storm Drainage
Sanitary Sewer
Backflow Device
Water Heater
Other
Final

- MECHANICAL
Gas Piping
Underfloor (P & B)
Rough Mechanical
HVAC (Final)
Other

- MANUFACTURED HOME
M/H Set-Up
M/H Mechanical
M/H Water/Sewer
M/H Electrical Feeder
M/H Final
Other

Comments:

[x] APPROVED
[x] NOT APPROVED (REINSPECTION REQUIRED)
[] APPROVED AFTER CORRECTIONS (NO REINSPECTION REQUIRED)
[] STOP WORK

CORRECTIONS:
P & B OK
NO Insulation To be installed

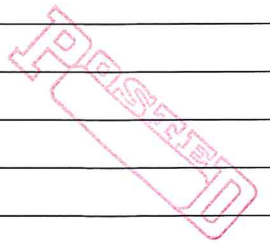

Date: 8-31-05 Inspector: [Signature]

City of Forest Grove

366 BLUEJAY AVE.

Light and Power Review

Single Family Residential

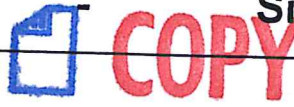

1. Builder to locate meter base on WEST wall of GARAGE within 3 feet of the front corner of the structure, or as follows: _____

2. If underground service, builder to provide and install 3" Sch. 40 PVC conduit (maximum of three (3) 90 degree bends) from the meter base to the pedestal (or pole) located at:

NORTHEAST CORNER OF LOT, SEE ATTACHED RED-LINED SITE PLAN...

Light & Power Department to inspect conduit installation prior to backfilling.

Contact L&P Dept. for specifications.

3. Utility-provided temporary construction service, including permit, is available for a \$150.00 fee. In addition, line extension fees are charged if the cost to connect to the Utility System exceeds a pre-set allowance. Contact the City Light & Power Department at (503)992-3250.

Comments: The City of Forest Grove Light & Power Dept. can provide and install the duct run for U.G. power service for an additional cost. Contact the Light & Power Dept. for information.

NOTE: If service is to be over 200 amps, 4" Sch. 40 PVC duct must be installed. If service is to be 400 amps or more, contact Light & Power Dept.

Additional comments:



COMMUNITY DEVELOPMENT DEPARTMENT
Building and Code Enforcement

INSPECTION REQUEST

503-992-3206

Site Address 366 Blue Jay
Contractor
Phone Number

Scheduled Inspection Date 10-27-05
Mon [] Tues [] Wed [] Thurs [X] Fri []
AM [] PM [] other
Permit Number MECOS-000094

- BUILDING: Footing / Pier, Foundation Wall, Underfloor (P & B), Shear, Framing, Insulation, Approach/Sidewalk, Other, Planning, Final
PLUMBING: Underfloor (P & B), Top Out (Rough), Water Line, Rain/Crawl Drains, Storm Drainage, Sanitary Sewer, Backflow Device, Water Heater, Other, Final
MECHANICAL: Gas Piping, Underfloor (P & B), Rough Mechanical, HVAC (Final), Other
MANUFACTURED HOME: M/H Set-Up, M/H Mechanical, M/H Water/Sewer, M/H Electrical Feeder, M/H Final, Other

Comments:

- [X] APPROVED
[] NOT APPROVED (REINSPECTION REQUIRED)
[] APPROVED AFTER CORRECTIONS (NO REINSPECTION REQUIRED)
[] STOP WORK

CORRECTIONS: 14 lbs For 15 min

Tag # 358254



Date: 10-27-05 Inspector: [Signature]



COMMUNITY DEVELOPMENT DEPARTMENT
Building and Code Enforcement

INSPECTION REQUEST

503-992-3206

Site Address: 366 Bluejay Ave
Contractor: John
Phone Number: 522-1571

Scheduled Inspection Date: 10/27/05
Mon [] Tues [] Wed [] Thurs [] Fri [x]
AM [x] PM [] other []
Permit Number: 05-20096

BUILDING

PLUMBING

MECHANICAL

MANUFACTURED HOME

- Footing / Pier
Foundation Wall
Underfloor (P & B)
Shear
Framing
Insulation
Approach/Sidewalk
Other
Planning
Final

- Underfloor (P & B)
Top Out (Rough)
Water Line
Rain/Crawl Drains
Storm Drainage
Sanitary Sewer
Backflow Device
Water Heater
Other
Final

- Gas Piping
Underfloor (P & B)
Rough Mechanical
HVAC (Final)
Other

- M/H Set-Up
M/H Mechanical
M/H Water/Sewer
M/H Electrical Feeder
M/H Final
Other

Comments:

[x] APPROVED

[] NOT APPROVED (REINSPECTION REQUIRED)

[] APPROVED AFTER CORRECTIONS (NO REINSPECTION REQUIRED)

[] STOP WORK

CORRECTIONS:

OK To Cover - Framing approved, completed Mech corrections

POSTED

Date: 10-27-05

Inspector: [Signature]



COMMUNITY DEVELOPMENT DEPARTMENT
Building and Code Enforcement

INSPECTION REQUEST

503-992-3206

Site Address 366 Blue Jay Ave
Contractor John
Phone Number 503-522-1571

Scheduled Inspection Date 10/25/05
Mon [] Tues [x] Wed [] Thurs [] Fri []
AM [x] PM [] other
Permit Number MEC0500094

BUILDING

PLUMBING

MECHANICAL

MANUFACTURED HOME

- Footing / Pier
Foundation Wall
Underfloor (P & B)
Shear
Framing
Insulation
Approach/Sidewalk
Other
Planning
Final

- Underfloor (P & B)
Top Out (Rough)
Water Line
Rain/Crawl Drains
Storm Drainage
Sanitary Sewer
Backflow Device
Water Heater
Other
Final

- Gas Piping
Underfloor (P & B)
[X] Rough Mechanical RE
HVAC (Final)
Other

- M/H Set-Up
M/H Mechanical
M/H Water/Sewer
M/H Electrical Feeder
M/H Final
Other

Comments:

[] APPROVED

[x] NOT APPROVED
(REINSPECTION REQUIRED)

[] APPROVED AFTER
CORRECTIONS
(NO REINSPECTION REQUIRED)

[] STOP WORK

CORRECTIONS: 1) complete gas line to fire place

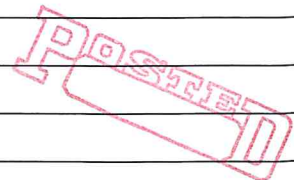

Date: 10-25-05

Inspector: [Signature]



COMMUNITY DEVELOPMENT DEPARTMENT
Building and Code Enforcement

INSPECTION REQUEST

503-992-3206

Site Address 366 Bluejay Ave
Contractor
Phone Number

Scheduled Inspection Date 10/25/05
Mon [] Tues [x] Wed [] Thurs [] Fri []
AM [x] PM [] other
Permit Number BLD05-000916

BUILDING

- Footing / Pier
Foundation Wall
Underfloor (P & B)
Shear
[x] Framing RE
Insulation
Approach/Sidewalk
Other
Planning
Final

PLUMBING

- Underfloor (P & B)
Top Out (Rough)
Water Line
Rain/Crawl Drains
Storm Drainage
Sanitary Sewer
Backflow Device
Water Heater
Other
Final

MECHANICAL

- Gas Piping
Underfloor (P & B)
Rough Mechanical
HVAC (Final)
Other

MANUFACTURED HOME

- M/H Set-Up
M/H Mechanical
M/H Water/Sewer
M/H Electrical Feeder
M/H Final
Other

Comments:

[] APPROVED

[x] NOT APPROVED
(REINSPECTION REQUIRED)

[] APPROVED AFTER
CORRECTIONS

[] STOP WORK

CORRECTIONS: NEED to complete mech (GAS line to fireplace)

Note: OK to insulate

FRAMING corrections completed

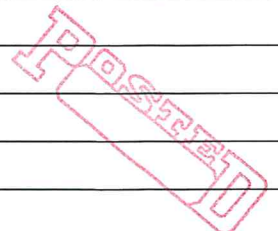

Date: 10.25.05

Inspector: [Signature]

LOT 4 5,699 sq ft

Holscher Farm

Bluejay AV

IN 435AA 1301

House 2555 sq ft

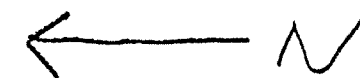

PRELIMINARY

LOT SLOPES to South - NOT FOR CONSTRUCTION -
downward Apprx 3 1/2' within building envelope

BUILDING CONTRACTOR IS REQUIRED TO CONTACT THE CITY OF FOREST GROVE LIGHT AND POWER DEPARTMENT, AFTER THE ELECTRICAL BACKBONE SYSTEM HAS BEEN INSTALLED IN THIS SUBDIVISION, FOR FINAL SITE/BUILDING PLAN REVIEW TO OBTAIN APPROVAL...

APPROX. LOCATION OF PROPOSED PAD MT. TRANSFORMER, (8FT. MIN. CLEARANCE TO STRUCTURE, ETC... SEE ATTACHMENT.)

APPROX. LOCATION OF PROPOSED SECONDARY POWER PEDESTAL...

CITY OF FOREST GROVE
LIGHT & POWER DEPT.
1818 B. STREET
P.O. BOX 326
FOREST GROVE, OR 97116

N - 7/28/05

NOTE: THIS SUBDIVISION HAS NOT BEEN CONSTRUCTED YET, NO ELECTRICAL POWER IS AVAILABLE TO THIS LOT AT THIS TIME. THE LIGHT AND POWER DEPT. WILL NOT SIGN OFF ON FINAL APPROVAL OF THIS BUILDING PLAN UNTIL THE ELECTRICAL BACKBONE SYSTEM HAS BEEN COMPLETED FOR THIS SUBDIVISION. ELECTRICAL SERVICE WILL NOT BE PROVIDED FOR THIS HOUSE UNTIL SITE/PLAN REVIEW HAS BEEN COMPLETED AND APPROVED BY THE LIGHT AND POWER DEPT.

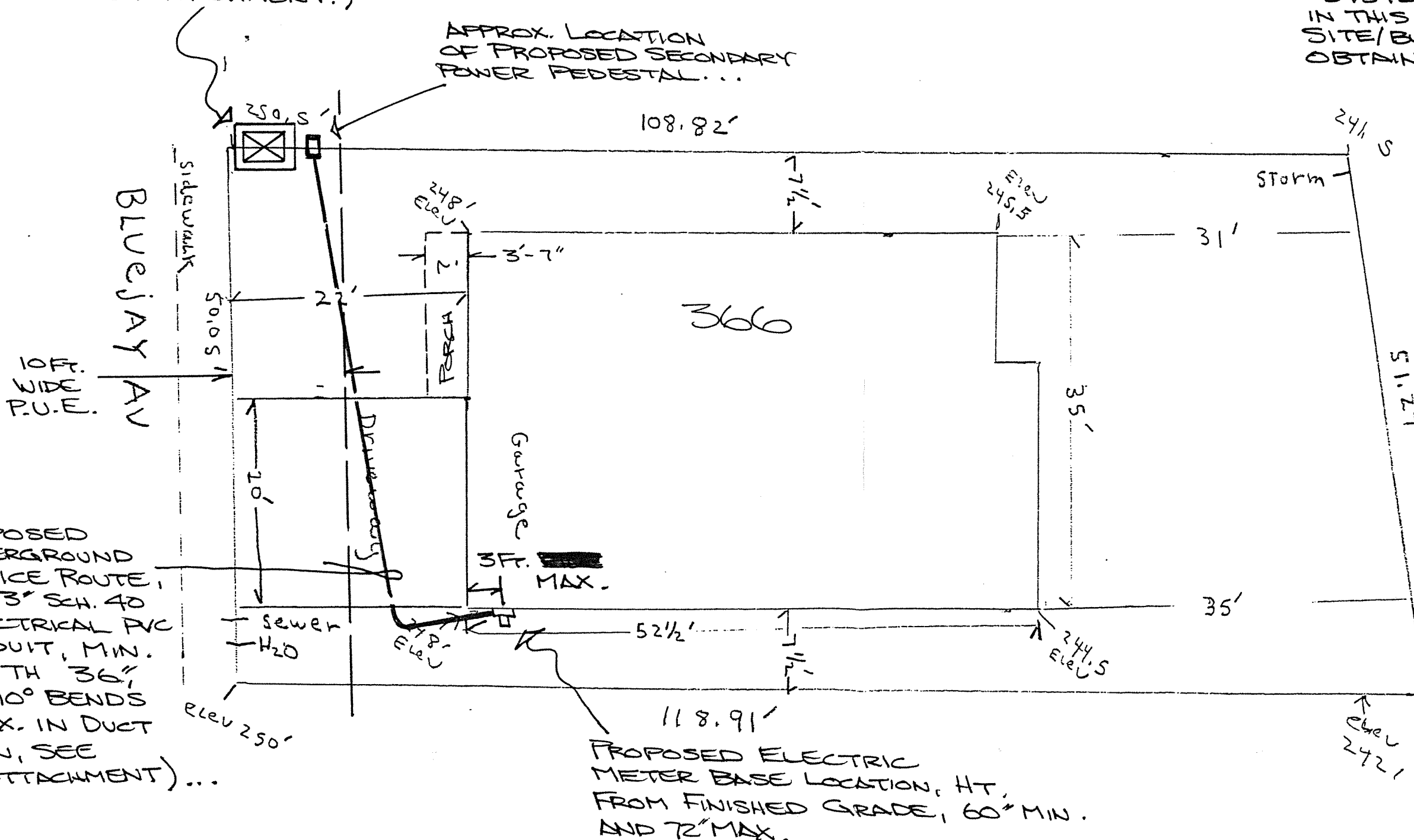

PROPOSED UNDERGROUND SERVICE ROUTE, USE 3" SCH. 40 ELECTRICAL PVC CONDUIT, MIN. DEPTH 36" (3-90° BENDS MAX. IN DUCT RUN, SEE ATTACHMENT)...

PROPOSED ELECTRIC METER BASE LOCATION, HT. FROM FINISHED GRADE, 60" MIN. AND 72" MAX.

LOT 4 5,699 ~~sq~~
 HOLSCHER FARM
 BLUEJAY AV
 IN 435AA 1301
 House 2555 ~~sq~~



LOT SLOPES to South
 downward Apprx 3 1/2'
 within building
 envelope

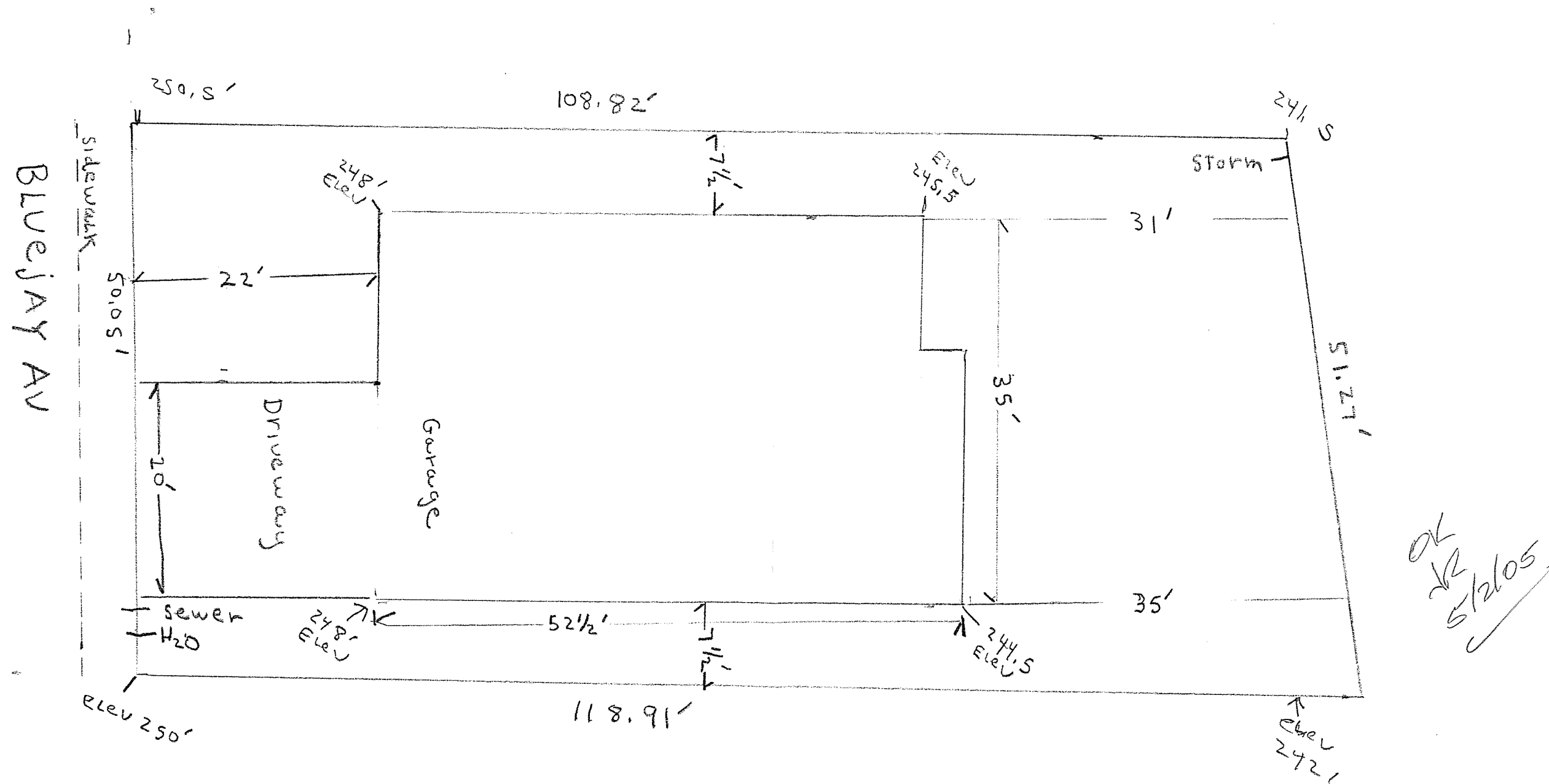



Building Permit

Residential Mechanical

311-17-000543-MECH

CITY OF FOREST GROVE

1924 Council St
 Forest Grove, OR 97116
 503-992-3229
 Fax: 503-992-3202

www.forestgrove-or.gov

cd@forestgrove-or.gov

Permit Issued: July 13, 2017

Job Name: BATES

TYPE OF WORK

Type of Work: Alteration
 Submitted Value: \$10,685.00

Category of Construction: Single Family Dwelling
 Description of Work: REPLACE EXISTING GAS FURNACE AND A/C UNIT

JOB SITE INFORMATION

Property Address:
 366 Bluejay Ave, Forest Grove,
 OR 971161379

Parcel:
 1N435AA10100 - Primary

Owner: BATES SHELDON H & MIA J
 Address: 366 BLUEJAY AVE
 FOREST GROVE OR
 97116379

LICENSED PROFESSIONAL INFORMATION

Business Name	License	License Nbr	Phone
ABLE HEATING & COOLING LLC	CCB	184392	503-579-2250

INSPECTIONS - Additional inspections may be required through the life of the project.

The list of inspections below represents the minimum inspections recommended for this project at the time of permit printing.

2999 Final Mechanical

Schedule Inspections online at www.buildingpermits.oregon.gov or by calling: 1-888-299-2821

When calling for an inspection, use **IVR Number: 311033244305**

OR search "ePermitting" at the Apple App Store to download the **Oregon ePermitting Inspection App** for iOS.

OR search "ePermitting" at the Android App Store to download the **Oregon ePermitting Inspection App** for Android.

PERMIT FEES - Permit fees may change after staff review

Fee Description	Quantity	Amount
Air conditioner	1 Ea	\$11.90
Furnace - up to 100,000 BTU	1 Ea	\$11.90
Balance of minimum permit fees - mechanical		\$3.50
State of Oregon Surcharge - Mech (12% of applicable fees)		\$3.28
Total Fees:		\$30.58

Permits expire if work is not started within 180 Days of issuance or if work is suspended for 180 Days or longer depending on the issuing agencies policy.

All provisions of laws and ordinances governing this type of work will be complied with whether specified herein or not. Granting of a permit does not presume to give authority to violate or cancel the provisions of any other state or local law regulating construction or the performance of construction.

ATTENTION: Oregon law requires you to follow rules adopted by the Oregon Utility Notification Center. Those rules are set forth in OAR 952-001-0010 through OAR 952-001-0090. You may obtain copies of the rules by calling the center. (Note: the telephone number for the Oregon Utility Notification Center is (503) 232-1987).

All persons or entities performing work under this permit are required to be licensed unless exempted by ORS 701.010.

Forest Grove Inspection Report

1924 Council Street
Forest Grove, OR 97116

Tel: (503)992-3229

Location:
366 BLUEJAY AVE, FOREST GROVE,
WASHINGTON, OR, 971161379, UNITED

Inspection Date:

Record Type:
Residential Mechanical

Record ID:
311-17-000543-MECH

Inspection Type:
2999 Final Mechanical

Inspector:
Andrew Wilson

Result:
Approved

Comments:

Violation Summary:



Inspector

Contractor