

**RESOLUTION NO. 17-26**

---

**A RESOLUTION DECLARING AN EMERGENCY AND EXEMPTING CLACKAMAS COUNTY MODULAR TINY HOME ASSEMBLY FROM PLANNING CODE REQUIREMENTS AND PROCESSES ON A TEMPORARY BASIS**

**WHEREAS**, Oregon City Municipal Code (OCMC) 2.52.020 defines “emergencies” to include “any man-made or natural event or circumstance causing or threatening loss of life, injury to person or property, human suffering or financial loss, and includes, . . . contamination, . . . , blight, [and] infestation;” and

**WHEREAS**, OCMC 2.52.040(L) authorizes the City, in cases of emergency to “order such other measures as are necessary for the protection of life or property, or for the recovery from the emergency;” and

**WHEREAS**, Clackamas County is assembling approximately 30 modular tiny homes in Parking Lot F on the Red Soil Campus located at Clackamas County Map 3-2-E-5C, Tax Lot 812 that will be made available to veterans who lack housing; and

**WHEREAS**, once assembled, the modular tiny homes will be relocated to a County owned property outside of Oregon City; and

**WHEREAS**, the City Commission of Oregon City adopted Goal #3 for the 2017-2019 biennium to “Enhance the Livability of the Community;” and

**WHEREAS**, Goal #3 includes the following sub-goals “Identify partnerships/programs and funding to address houseless community members;” and “Work with regional partners to identify tools and programs to increase affordable housing and housing affordability;” and

**WHEREAS**, the modular tiny homes are being constructed for houseless veterans, in support of the City Commission Goal #3; and

**WHEREAS**, the City Commission previously approved Resolution 17-22 exempting the project from August 3, 2017 until October 31, 2017; and

**WHEREAS**, Clackamas County requested the Emergency be extended until February 28, 2018.

**NOW, THEREFORE, OREGON CITY RESOLVES:**

**Section 1.** The City Commission hereby declares an emergency limited to Parking Lot F on the Red Soils Campus located at Clackamas County Map 3-2-E-5C, Tax Lot 812, to accommodate the temporary construction of modular tiny homes for houseless veterans as proposed. The emergency is declared consistent with OCMC 2.52.070 and, by this resolution, the Commission extends the time of this emergency until February 28, 2018.

**Section 2.** Based on the emergency identified above, the City Commission grants Clackamas County an exemption from the Oregon City Zoning Code for the temporary construction of modular tiny homes for houseless veterans as proposed Parking Lot F on the Red Soils

Campus located at Clackamas County Map 3-2-E-5C, Tax Lot 812 for the duration of the emergency.

**Section 3.** Due to the anticipated temporary nature of the project, System Development Charges will not be assessed during the emergency.

**Section 4.** This resolution shall take effect immediately.

Approved and adopted at a regular meeting of the City Commission held on the 1st day of November 2017.



DAN HOLLADAY, Mayor

Attested to this 1st day of November 2017:

  
Kattie Riggs, City Recorder

Approved as to legal sufficiency:

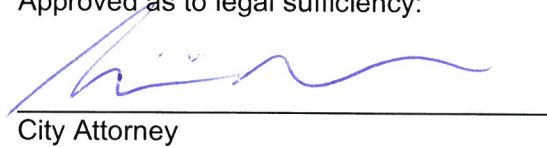
  
City Attorney

Exhibits:

1. Clackamas County Request
2. Site Map



**BOARD OF COUNTY COMMISSIONERS**

**PUBLIC SERVICES BUILDING**  
2051 KAEN ROAD | OREGON CITY, OR 97045

October 24, 2017

City of Oregon City  
Mayor and Commissioners  
625 Center Street  
Oregon City, OR 97045

Dear Mayor and Commissioners:

Our transitional shelter community project for veterans has made great progress. In the last several weeks the community has rallied in support and together we have built 10 sleeping pods! Thank you for your enthusiastic partnership and specifically to those city commissioners who came and participated with us at our construction kickoff event on October 14.

Your approval of Resolution 17-22, Declaring an Emergency and Exempting Clackamas County Modular Tiny Home Assembly from Planning Code Requirements and Processes on a Temporary Basis, allowed us the opportunity to take an important step in our plan to create a shelter serving our community's houseless veterans. We have worked diligently to expedite our land use process timeline in order to be able to open this shelter before the coming winter season. Despite our best efforts, the land use hearing for the conditional use permit could not be scheduled before the end of November. We also have five remaining sleeping pods to construct in order to meet our goal of 15 pods. This delay has caused a ripple effect and we will not be able to move the pods to the proposed site before the City resolution's deadline of October 31. While we could work to find a temporary storage site for these pods this would be a costly and time consuming endeavor that would take resources away from the ultimate goal of keeping veterans out of the cold weather.

Given these circumstances, we respectfully request the opportunity to finish construction on the remaining 5 sleeping pods and store them all onsite until we are able to site them at the proposed location near SE 115<sup>th</sup> and Jennifer. An initial conversation between Commissioner Schrader and Mayor Holladay indicated that this extension request would be favorably received. If there is a need to guarantee our commitment to move the pods with some sort of security, we are willing to do so.

We appreciate your consideration of this request. We know you join us in supporting our mutual community goal to end veterans' houselessness.

Sincerely

Jim Bernard, Chair  
On Behalf of the Clackamas County Board of Commissioners



**OFFICE OF THE COUNTY ADMINISTRATOR**

**PUBLIC SERVICES BUILDING**  
2051 KAEN ROAD | OREGON CITY, OR 97045

August 9, 2017

Laura Terway, Community Development Director  
City of Oregon City  
221 Molalla Ave, Ste 200  
Oregon City, OR 97045

Dear Ms. Terway,

I am writing on behalf of the Clackamas County Board of Commissioners (The Board) to request the use of property on the Red Soils Campus for the temporary storage and assembly of transitional housing pods. The Board has undertaken a unique project to provide safe, sanitary and secure shelter for houseless veterans in Clackamas County. Partnerships have been formed with local non-profit organizations (Catholic Charities, Portland State University – Center for Public Interest and Design, and City Repair) to construct up to 30 sleeping pods for a village community that will be located in unincorporated Clackamas County.

Construction materials have been donated and made available now for this purpose. The Board respectfully requests the opportunity to store these necessary materials and to assemble the sleeping pods on the Clackamas County Red Soils campus. The proposed site is marked "Construction Storage Area" on the attached map. The recent availability of these materials, the process of amending the zoning ordinance and the deadline to complete the village by the end of the year have all contributed to the timing of this urgent request.

**Background**

The Board set aside \$300,000 to construct up to 30 sleeping pods to be in place no later than the end of 2017. The Health, Housing and Human Services (H3S) department began conversations with local non-profit organizations who could facilitate both the construction and operation of a shelter site. Catholic Charities has been selected as the primary partner organization. Together H3S and Catholic Charities have been working with representatives from Portland State University and City Repair to obtain construction materials. Pick-a-thon is an annual concert event held in Clackamas County. The stage trusses are being used in the design of the sleeping pods. The stage has been deconstructed and these valuable materials have been made available now for this project.

At Board direction, a Zoning and Development Ordinance amendment process was begun. An amendment was drafted to allow transitional shelter communities, also known as villages, in the unincorporated industrial areas of Clackamas County. This amendment went through the full public process with the Planning Commission and was just accepted by the Board on Wednesday, August 2<sup>nd</sup>. The County will soon be able to accept applications for a conditional use permit to use small parcels of government-owned land to site these transitional shelter communities. The temporary placement of

the materials for the pods on the Red Soils Campus are intended to be used at a site identified for a transitional shelter facility. However, additional land use applications are necessary before the site can be further developed.

**Details of the Request**

Materials to construct 30 sleeping pods have just been made available and will be delivered August 9-11. Materials will be stored outside and in enclosed construction fencing at the Red Soils Parking Lot F, and inside the Juvenile Skills Center. Parking Lot F is a large gravel parking lot, the proposed construction area measures approximately 238' x 130'.

This area has dedicated electrical circuits/receptacles mounted to the side of the Juvenile Skills Center. Hose bibs for minimal use of water is also available. Existing buildings in close proximity to the construction area will provide adequate restroom facilities for staff and volunteers. Activities will be coordinated by representatives from the non-profits, a building steward and performed by volunteers on site. Construction activities to assemble the pods will begin at the end of August and are planned to continue through the end of October 2017.

Attached are the designs for the sleeping pod structures. Once constructed, the sleeping pods will be moved to another county owned site in unincorporated Clackamas County no later than the end of November 2017. All other remaining construction materials, fencing and equipment will be removed from the premises restoring it to its current state.

Allowing use of this construction space temporarily on the Red Soils Campus is essential to the progress of the veterans shelter project and is an important step towards resolving veterans houselessness in Clackamas County. I believe both the Board of County Commissioners and the Oregon City Commissioners are committed to addressing the urgent needs of the houseless in our communities.

Thank you for your consideration of this request. County Commissioners and staff stand ready to speak to the importance of this project, this specific request and answer any questions. Please feel free to contact me directly to coordinate an opportunity to meet if necessary.

Thank you,



Don Krupp, Administrator  
Clackamas County





# POD INITIATIVE

PARTNERS ON DWELLING



**SRG**





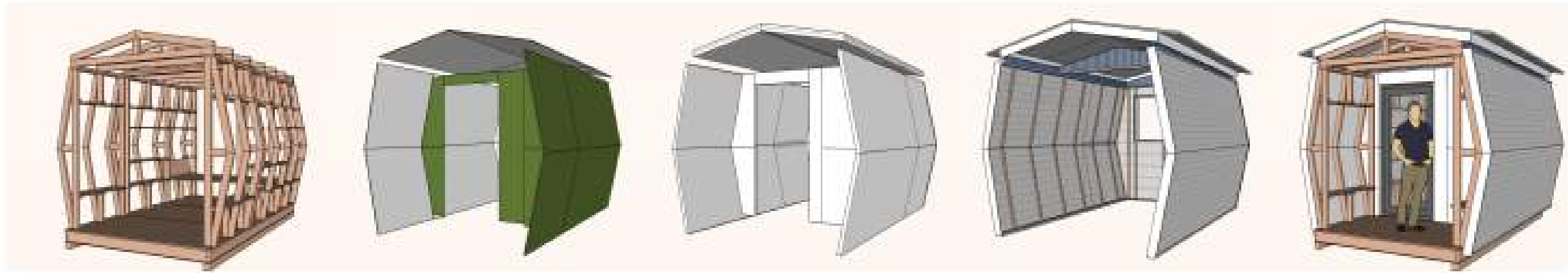

Total Material needed for Primary Truss Assembly (17 Trusses Total):  
 (100) SDWC Screws (varied lengths)  
 (288) Screws  
 (34) 8' long 2x4's  
 (5) 8' long 2x2's

Total Material needed for Intermediate Truss Assembly (6 Trusses):  
 (48) Screws  
 (9) 8' long 2x4  
 (3) 8' long 2x2

Total Material needed for Platform and Roof Assembly:  
 (3) 7/16" thick 4x8 OSB Roof Underlayment  
 (3) 3/4" CDX Plywood Roof Deck  
 (3) 3/4" thick 4x8 Plywood Floor Deck  
 (3) 3/8" thick 4x8 CDX Plywood Board below  
 (10) 8' long 2x4's  
 (2) 12' long 2x4's  
 (2) 12' long 4x6's (skids)

Total Material needed for End Wall Framing and Windows:  
 (16) 8' long 2x4's  
 (1) 3'-0" Full Lite Swing Door (can vary)  
 (1) 2'-10"x4'-0" Slider Window (can vary)  
 (1) 1/2" thick 4x8 Polycarbonate Panel  
 (1) 1/2" thick 4x4 Polycarbonate Panel + Associated flashing

Total Material needed for Trim and Rainscreen Support:  
 (3) 3/4" thick 4x8 Ext Grade Plywood Sheets

Total Material needed for Sheathing/Weather barrier:  
 (10) 7/16" 4x8 Zip Panels (clads roof and walls)  
 (2) 75' Rolls of Zip Tape

Total Material needed for roof and wall insulation:  
 (13) 2" 4x8 Polyiso Sheets  
 (3) 1 1/2" 4x8 Polyiso Sheets (2" walls thickness, 3 1/2" roof thickness)

Total Material needed for Roof:  
 (4) 10x3 Metal Roofing Panels + Associated flashing (Gutters optional)

NOTE : CLADDING MATERIAL TBD BY OWNER.  
 OPTIONS INCLUDE EXTERIOR GRADE PLYWOOD, FIBER CEMENT SIDING, CORRUGATED METAL, LAP SIDING, ETC.

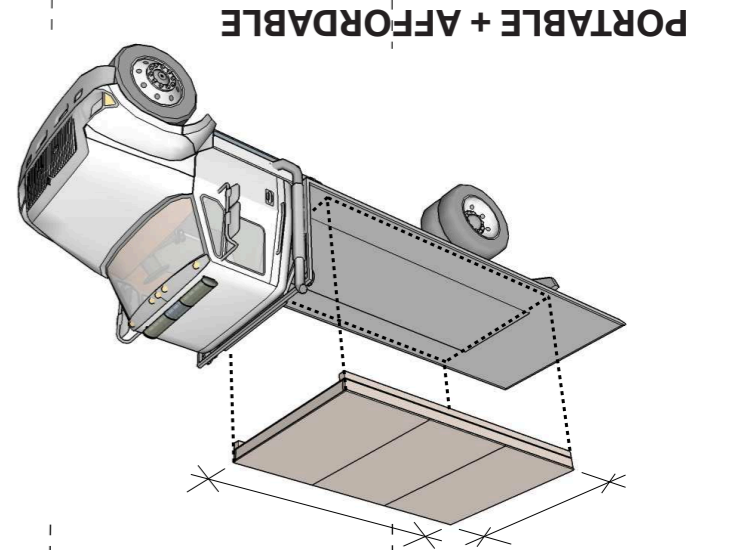
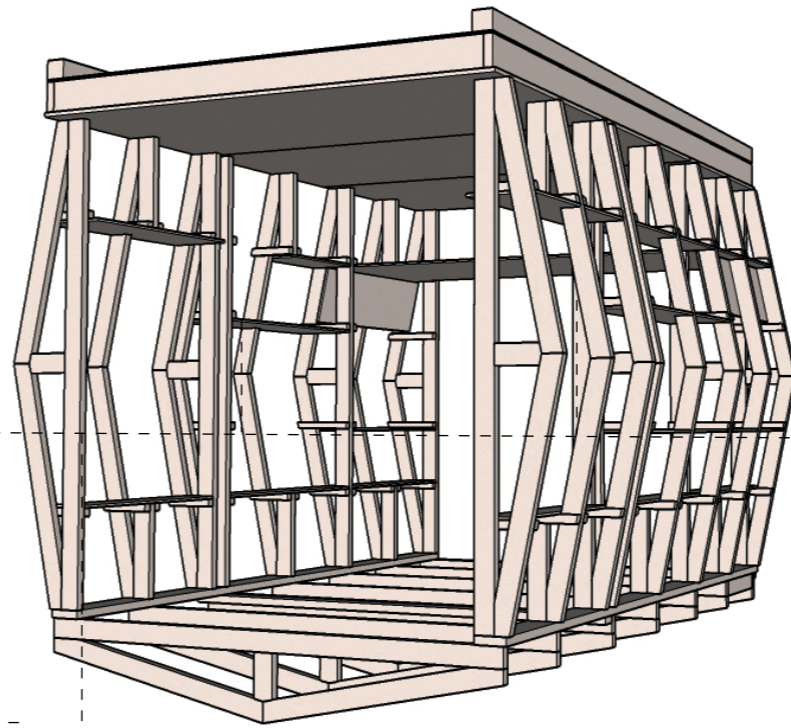
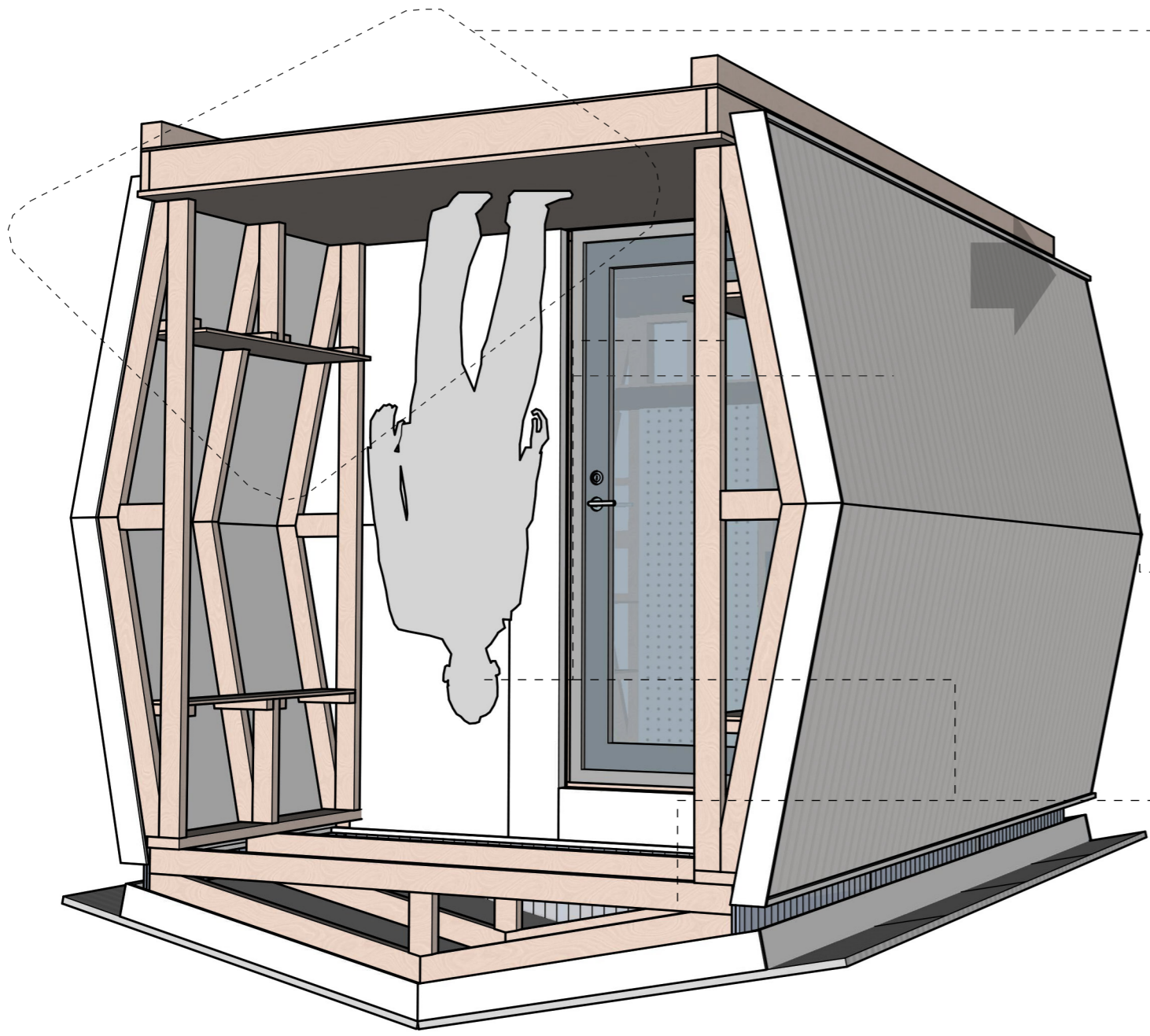

**PORTABLE + AFFORDABLE**

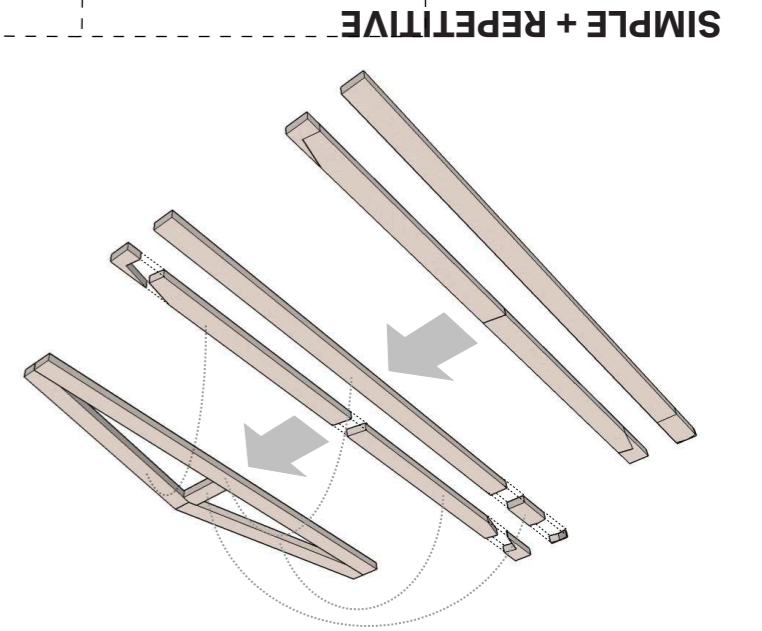

**SIMPLE + REPETITIVE**

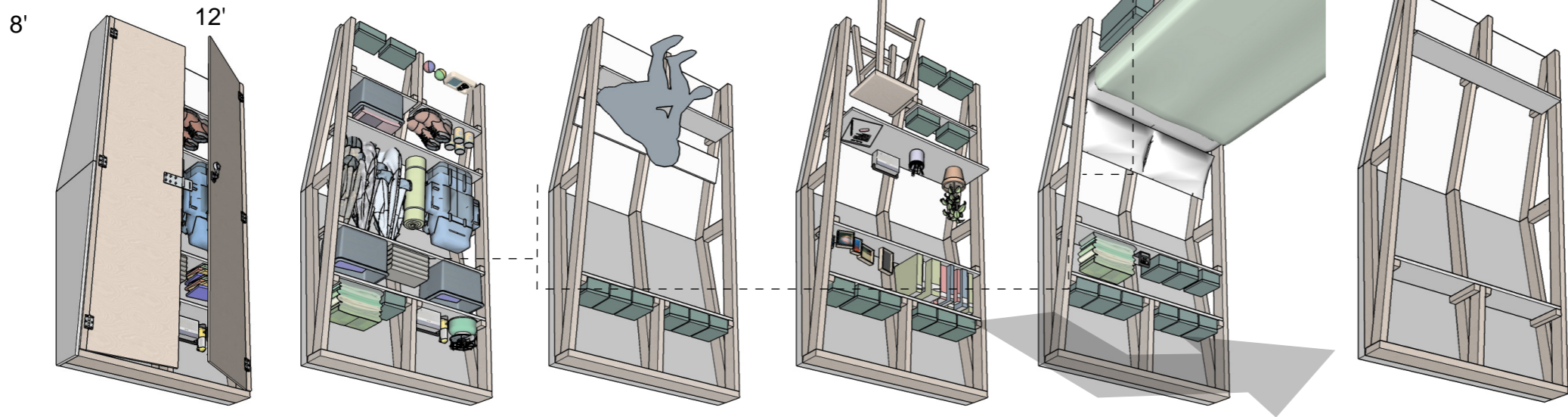

8'

12'

**FUNCTIONAL + EFFICIENT**

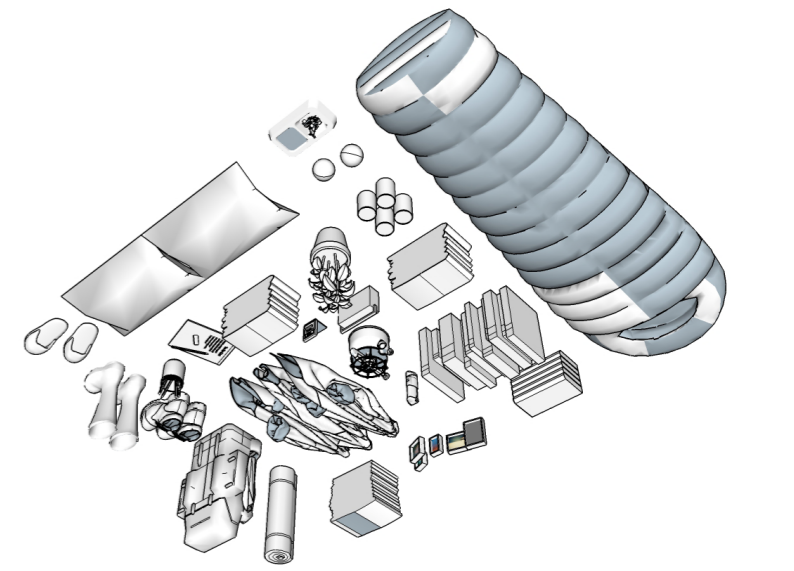

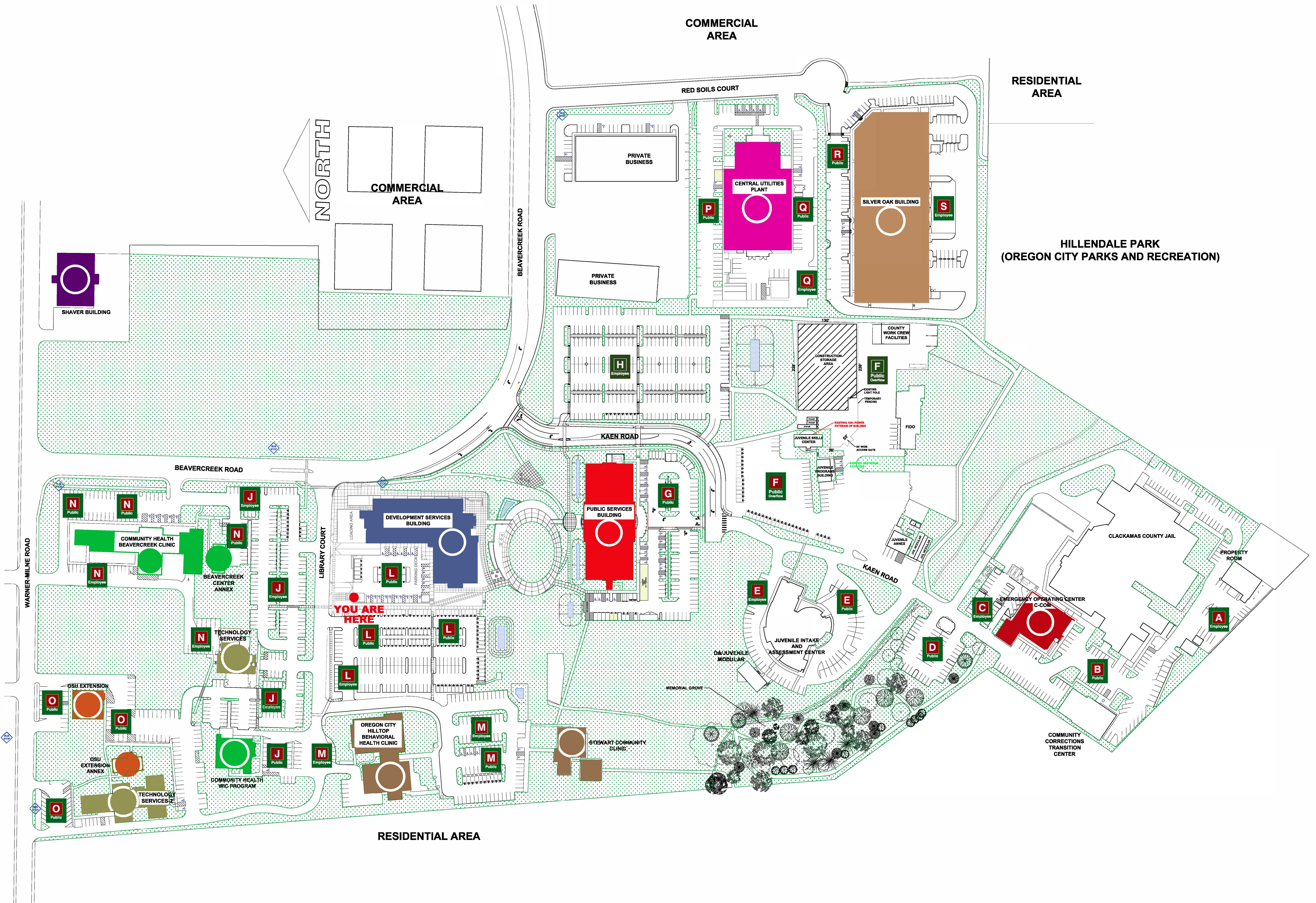

CLACKAMAS COUNTY  
 FACILITIES MANAGEMENT  
 1740 RED SOILS CT #200  
 OREGON CITY, OR 97045  
 PH: (503) 957-4411 FAX: (503) 957-4995

RED SOILS CAMPUS

DATE: 08/14/2017	WKS: 0000
SCALE: 1/8" = 1'-0"	DATE: 08/14

# HILLE (OREGON CITY PA

FACILITIES MANAGEMENT  
1710 RED SOILS CT #200  
OREGON CITY, OR 97046  
PH: (503) 537-6111 FAX: (503) 655-8658

PRIVATE  
BUSINESS



COUNTY  
WORK CREW  
FACILITIES

CONSTRUCTION  
STORAGE  
AREA

FIDO

JUVENILE  
SKILLS  
CENTER

JUVENILE  
PROGRAMS  
BUILDING

JUVENILE  
ANNEX

JAIL  
MODULAR

JAIL  
MODULAR

130'

238'

226'

36'

53'

EXISTING 120V POWER  
EXTERIOR OF BUILDING

24' WIDE  
ACCESS GATE

EXISTING RESTROOM  
FACILITIES

KAEN ROAD

KAEN

RED SOILS CAMPUS  
TINY HOUSE LAYDOWN YARD

DATE: 08AUG17  
REVISIONS:  
SCALE: 1/32" = 1'-0"  
DRAWN BY: BFB  
CHECKED BY:

FM#  
5100